

User Manual

Thank you for using our public address system. Please read this User Manual carefully to make better use of this equipment.

This page is left blank for memo.

About the Manual

This User Manual is available and effective upon completion of development of Network Public Address Center. The User Manual includes system description, matters needing attentions in use, instructions on system connection, instructions on use of product and technical specifications of Network Public Address Center. Please read this User Manual carefully before connection, installation and use and operate in accordance with corresponding instructions in the Manual.



This symbol on the rear panel indicates matters needing attentions, please use or operate the product in accordance with corresponding instructions.

Statement

This is a Class A product.

Warning: Operating this equipment in a residential environment may result in radio frequency interference.

V7.0

Facture 2025-11-13

Matters Needing Attention

Please read the following before operating the product.

Warning

The following basic requirements must be strictly observed, to avoid potential personal injury and equipment or property damages to you or any person nearby. The basic requirements include without limitation to the following:

Power source/power cable

- Please disconnect the device from power source by pulling the plug other than the power cord. Pulling the power cord may result in damages.
- Please keep the power cord away from heat source. Do not over-bend the power cord or place it anywhere it can be stepped on or may cause to trip.
- This is connected to power source via the plug and any failure or danger occurs, the user can disconnect the device from power source by pulling out the plug out from the socket, therefore, it is required that the power socket should be located somewhere with easy access.
- The device is not completely disconnected from power source when it is switched "OFF". For sake of safety, please disconnect the device from the socket if it is not in user.

Positioning

- Please disconnect the device from power source before relocating the device.
- For avoiding deformation of panels and damages to internal components, please do NOT place the device where there is heavy dust or violent vibration, or where it is extremely cold or hot.
- Please keep this device off water drops or splash or vase filled with water or any other articles of similar nature.

Connection

- Please disconnect other equipment from power source before they are connected to this product. Please tune volume to its minimum level before the device is powered ON or OFF.
- All terminals on the device marked with ' ' are live and dangerous, and should be connected by trained personnel.

When abnormal conditions are realized

- Please disconnect the device from power source immediately in case the power cord is worn or damaged or if the sound is suddenly cut off or any abnormal odor or smoke comes out from the device, and then have the device inspected and repaired by professional personnel.

Precautions in Operation

- Please do NOT insert any finger into any gap or opening of the device.
- Please prevent foreign objects (paper, plastics or metal etc.) from being inserted or falling into any gap or opening of the device. In such case, please cut off power source immediately.
- Please do NOT put the body or any heavy object on the device and do NOT operate the buttons or switches or connections with excessive force.

Do NOT Open

- Please do NOT remove the cover of the equipment, otherwise you may get an electric shock.
- Do NOT attempt to remove any internal component from the device, or to modify the equipment in whatever manner. In case of any abnormal condition, please stop using the device immediately and have it inspected and repaired by professional personnel.

Other Precautions

- Our company shall not be responsible for data loss or damages due to improper use of unauthorized modification to the device.
- The images and screen display in this Manual are only for description and may be different from screen images in actual operation. The screen

display depends on the product.

CONTENTS

System Overview	1
1. About Visual Network PA System	1
2. System Features	1
I. Network System Host	3
1.1 Host Features	3
1.2 Front Panel	4
1.3 Rear Panel.....	5
II Function Modules	6
2.1 Telephone Paging Module	6
2.1.1 Installation of Telephone Paging Module	7
2.1.2 Telephone Paging Module Settings on the Host	7
2.2 4-channel Audio Collection Module.....	9
2.2.1 4-channel Audio Collection Module Settings on the Host.....	10
2.3 Monitor Module.....	10
2.3.1 Monitor Module Settings on the Host	12
2.4 Hard Disk Module (Only the USB interface is available, other functions are built-in)	12
2.5 Main Power Expansion Module	13
2.5.1 Main Power Expansion Module Settings on the Host	13
2.6 Standby Power Expansion Module.....	14
2.6.1 Standby Power Expansion Module Settings on the Host	15
2.7 Switch Module.....	16
2.8 32-channel Fire Linkage Network Module.....	17
2.8.1 Features.....	17
2.8.2 Appearance Description.....	17
2.8.3 This Module Settings on the Host	18
2.8.4 Fire Channel Line Detection Function Settings.....	21
III. System Connection Diagram.....	22
3.1 Small System Connection Diagram.....	22
3.2 Small System Features	23
3.3 Typical System Connection Diagram	25
3.4 Typical System Features	26
IV. Operations and Settings	27
4.1 System Start-up Process	27
4.2 View System Working Status	28
4.2.1 View Zone Status.....	28
4.3 Play Programs for a Zone	29
4.3.1 Edit Program Groups	29
4.3.2 Control PC10 Peripherals Equipment.....	30
4.3.3 Play Programs for a Zone	34
4.3.4 Chime	38
4.3.5 Host Paging to a Zone	38
4.3.6 Alarm	39
4.3.7 Program Control	40

4.3.8 Zone Location.....	40
4.3.9 Audio Mixing Broadcast.....	41
4.3.10 Create and Call Timing Plan.....	42
4.3.10.1 Regular Timing Point Plan	42
4.3.10.2 Campus Timing Point Plan	51
4.3.11 Browse Timing Point Information	61
4.3.12 Video Preview.....	63
4.3.13 Adjust Zone Volume	63
4.3.14 IPC Video Preview	64
4.3.15 Program Pre-listening.....	64
4.3.16 Zone Monitoring.....	65
4.3.17 Shortcut Key 1 & Shortcut Key 2.....	66
4.3.18 Power Control.....	66
4.3.19 Broadcast Priority	66
V. System Settings	68
5.1 General Settings.....	68
5.2 Device Management.....	75
5.2.1 Device Information.....	75
5.2.2 Group Operation.....	88
5.2.3 Display Device	89
5.2.4 Device Parameters	90
5.2.5 Video Device Parameters.....	91
5.2.6 Ftp Parameters	92
5.3 Sound Source Management.....	92
5.3.1 Playlist.....	92
5.3.2 Host Song	93
5.3.3 USB Song	94
5.3.4 Program Recording.....	95
5.3.5 Alarm Sound Settings.....	95
5.3.6 Chime Settings.....	96
5.3.7 Sound Card Configuration.....	96
5.4 User Management.....	97
5.4.1 New User.....	97
5.4.2 Modify User.....	97
5.4.3 Delete User	98
5.5 Priority Settings	98
5.6 Network Settings	99
5.6.1 IP Management.....	99
5.6.2 Ping.....	100
5.7 Logs Management	100
5.7.1 Server Logs.....	100
5.7.2 Paging Station Logs.....	101
5.7.3 Device Logs.....	102
5.7.4 Voice Logs	102

5. 8 System Maintenance.....	103
5.8.1 Smart Paging Station	103
5.8.2 Device Maintenance	104
5.8.3 System Backup	105
5.8.4 Capture / Record.....	105
Packing List.....	107
Appendix Specifications.....	108

System Overview

1. About Visual Network PA System

Network Public Address System is a highly integrated and intelligent public address system based on computer network technology, modular and layered construction.

The system adopts fully digital transmission, with local area network as the main transmission medium, and transmits to any place covered by the network. It can use the existing local area network architecture for fast construction and investment saving, realize the integration of multiple networks with powerful interactive functions, and break through the functions of the traditional public address system that can only transmit to the next unit and can only be controlled through the centralized control of the computer room.

Network PA System Host can be compatible with terminals with different functions, including playback terminals, on-demand terminals, paging terminals, one-key emergency help terminals, etc. The host itself integrates audio and video player, partitioner, preamplifier, timer, powerful audio matrix functions, etc., which can realize audio and video intercom, media information release, audio and video storage, AI alarm, etc.

Network Public Address System is suitable for airports, docks, university towns, schools, large-scale gatherings (like Expo Park), sports stadiums, industrial parks, parks, rail transits and highways, etc

2. System Features

- Adopt distributed CS kernel framework and BS Web background service, support windows platform;
- Fully digital transmission, with LAN as the main transmission medium, can be transmitted to any place covered by the network.
- Use the existing LAN for fast construction and investment saving, and realize the integration of multiple networks.
- With powerful interactive functions, break through the functions of the traditional public address system that can only transmit to the next unit and can only be controlled through the centralized control of the computer room.
- Can combine zones and groups arbitrarily and reorganize them at any time without additional wiring.
- Can program the timing program. The system runs according to the pre-programmed program under unattended operation. Can manually or regularly play various types of work and rest ringtones every day. Can set the timing program independently for different zones, and can play different programs with different zone volumes at the same time.
- Play program on the terminals: The host can assign the play audio source to each zone one by one, or the terminal can play the program audio source on the host on demand independently.
- Overridden paging: The main control room can page a single zone or all zones on the host.
- Intercom function: If the system has set multiple zones, there can be multiple groups of one-to-multiple paging at the same time between the zones. And the two terminals can page and talk to each other.
- Video terminals management: It can support audio and video intercom, video surveillance, multi-screen display function, can display multi-screen display monitoring image through extended display screen.

-
- Remote control: The remote control computer can be any computer in the LAN, and should be installed with the control software of the system to operate, control and modify the system.
 - Equipped with a fire center interface, and auto overridden alarm, support short-circuit alarm (alarm card) and network signal alarm. When there is an alarm, the corresponding zone will display the fire alarm icon on the main interface, and the alarm status is clear at a glance.
 - After the terminal is disconnected and resumed, the playback will automatically resume at the same time, and the zone information will be automatically updated after modification.
 - The operation interface is more intuitive and user-friendly, and the zone name and group name can be changed at any time by using the full keyboard input.

I. Network System Host

1.1 Host Features

- With two servers and two databases, one master host and one backup unit, real-time synchronization, for dual-system hot backup function.
- 17.3" large color screen, with touch screen control.
- Using a key switch for a safer and more stable system.
- With powerful broadcast matrix, and built-in large-capacity program source capacity, can customize program sources as needed.
- With one-key alarm trigger for all zones and manual alarm functions.
- With TTS Chinese and English text broadcast function;
- With zone monitoring function to monitor the playback status and volume of zone terminals in real time.
- With zone paging function to directly page the zone on the host.
- Can add and display the new zone automatically, no need to set and restart the host.
- With auto on/off function, easy to use; with automatic screen saver function, energy-saving.
- With recording function. Can make your own program sources, which can be recorded by this machine, or copied from the remote control computer.
- With timing control function. Can edit the timing point on this machine, or download the timing point from the computer to the machine for execution.
- Equipped with a built-in CD player, with self-made CD player control interface.
- Can use the network paging terminal to expand the audio input channel.
- Adopt modular design, and can install network expansion modules, with more flexible function customization and easier maintenance.
- Adopt double solid-state hard disk design, with faster startup speed, better earthquake resistance and system stability.
- Adopt high-end industrial server motherboard design, dual network redundant backup.
- Can customize the bulk processing function of the <shortcut key> and customize the priority of the program audio source.
- Support Pinyin, five-stroke, stroke input method and so on.
- Support video terminals management, can video intercom, video monitoring, multi-screen display function, and display multi-screen images through the extended display screen.
- Support the binding of broadcast terminal with IPC.
- Support H264 video format.
- With offline functions of network microphone and network terminal.
- Support the access of intercom system.
- Support electronic map interactive management, and can customize the electronic map of the zone, with the electronic map status and operation functions.
- Support network radio playback and wireless push.

-
- Can remote control our company's PC10 peripheral equipment.
 - Mixing output is possible by connecting to a broadcast terminal with mixing function.
 - Supports linkage with mainstream cameras such as Hikvision and Dahua to achieve AI broadcast functions such as event triggering and event broadcasting.

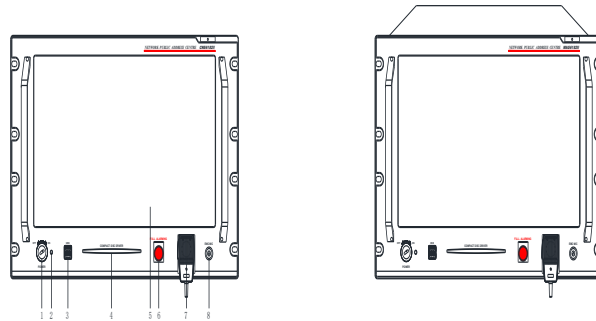

1. Key Switch (POWER)

The key switch is the power switch of the machine. Use the professional key of the network public address system host to turn on the power clockwise, and turn off the power counterclockwise. Do not turn on and off frequently, and the interval time between on and off should be more than 15s.

2. POWER LED

When the power is turned on, the indicator light stays green.

3. USB Port (USB)

The USB port is used to connect a USB flash disk, mobile hard disk or other storage devices to copy programs for the system. You can also connect a keyboard or mouse with a USB port for software upgrades and other operations.

4. Slot-in CD Jack

Manually insert the CD halfway into the jack, and then it will be sucked in automatically. You can use the "Eject" function on the software interface to eject the CD with one click.

5. Display Screen

The color display/touch screen can display various information of the machine in real time; and you can

directly touch the screen to operate the function items.

6. One-key Alarm Trigger Button (FULL ALARMING)

The signal sent by the button has the second priority, which is second only to the emergency paging microphone (7). As an emergency alarm trigger button, when an emergency occurs, all zones will be automatically opened after pressing this button, and an alarm signal will be sent to all zones. In the alarm state, the button lights up in red. At this time, press the button again to end the alarm.

7. Hand-held Emergency Paging Microphone Holder

When the emergency paging microphone is not in use, hang the microphone here.

8. Handheld Emergency Paging Microphone Jack (EMC MIC)

The hand-held emergency paging microphone has the highest priority. When the microphone talk switch is pressed, all zones are automatically opened, and all other signals are in waiting state. (For the operation of emergency paging microphone CB-100, please refer to its user manual, which will not be repeated here.)

1.3 Rear Panel

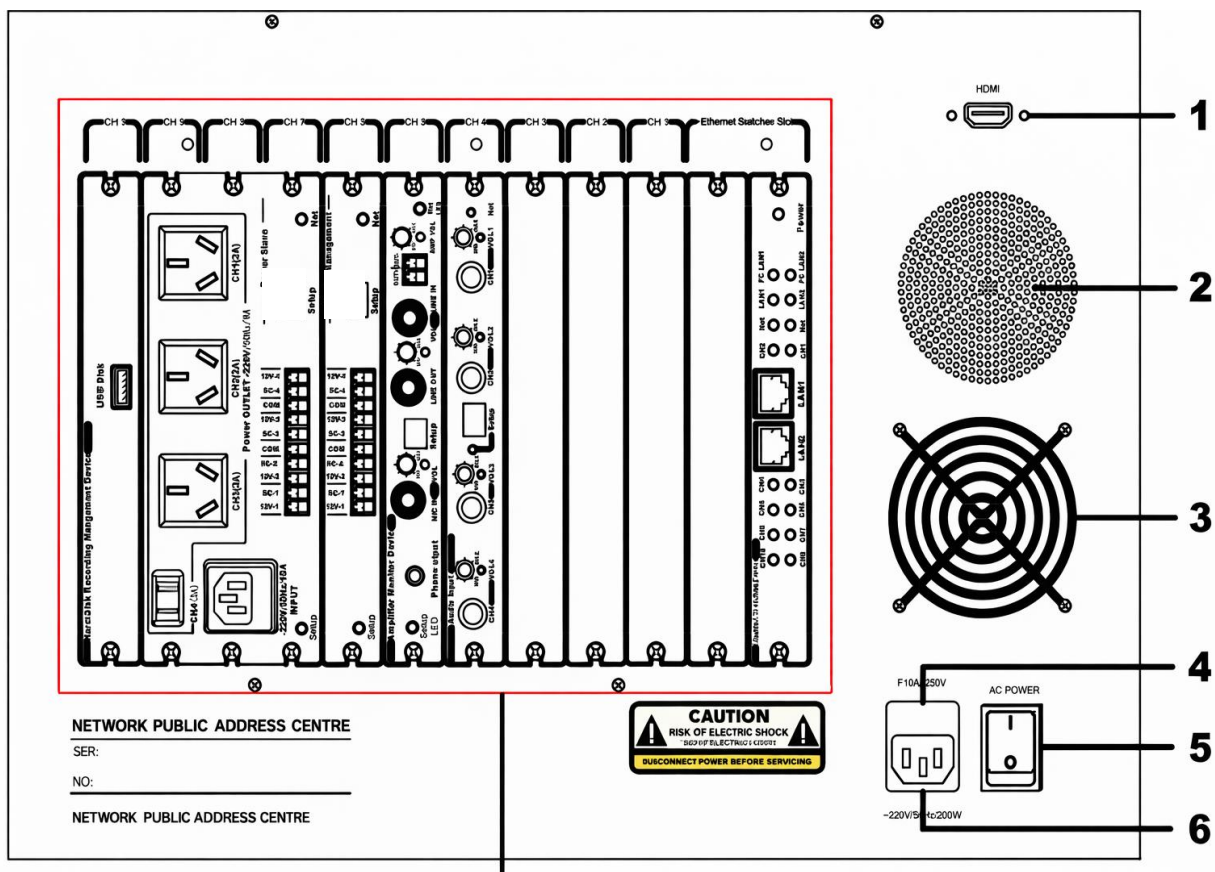

1. Data Exchange Interface (HDMI)

Connect the function module expansion box.

2. Speaker

3. Cooling Vent

When placing the machine, do not lean against the wall, and do not block the cooling vent.

4. Power Fuse Holder

If the fuse is blown, please replace it with a fuse of the same specification. For the specification of the fuse, please refer to the label next to the blown fuse or the product performance index specification table; if the fuse continues to blow, there is a short-circuit fault inside the machine. Please remove the fault and replace the fuse.

5. Power Input Plug

The power supply of this machine is AC220V ($\pm 10\%$). Please make sure that the voltage value of the power input to the machine matches that of the machine.

6. Function Module Expansion Port (Note: This machine needs to be equipped with 6 standard expansion modules to work normally!)

The 6 standard expansion modules include a switch module, 4-channel audio collection module, a monitoring module, a hard disk module, and a power supply main/standby expansion modules. The user can expand other required modules according to their needs.

7. Power Switch

II Function Modules

2.1 Telephone Paging Module

The phone paging module is a fully digital network PSNT analog telephone access to digital transmission switch based on the TCP/IP transmission protocol. The analog telephone can be transmitted to the public address system through the local telephone interface to achieve seamless combination with the traditional intercom system. Also, it adopts dual-tone multi-frequency automatic identification, and has a telephone-level control function.

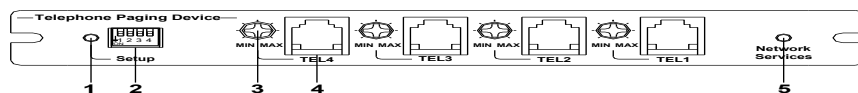

1. DIP LED

When one of the 4 dialing buttons is pressed down, this indicator light will be on.

2. DIP Switch

When the parameters of this module cannot be found, and if the IP is not clear, press one of the 4 dialing buttons, the indicator light will be on, and the parameters of this machine will be restored to the following specific parameters:

IP: 192.168.18.2 GATE: 192.168.18.1

Mask Code: 255.255.255.0

Main server IP: 192.168.18.250 Standby server IP: 192.168.18.251

3. **Input Level Control**

Adjust this knob according to the level of the input audio source signal.

4. **Telephone Input Interface**

Four telephone interfaces, connected to four telephone lines respectively.

5. **Network LED**

The indicator light will turn green when the phone paging module is disconnected, and the indicator light will turn red when it is successfully connected to the host through the network.

Features:

- Modular design, each module can input 4 telephone lines at the same time.
- Built-in voice menu prompt function.
- Dual network interface design, the network expansion port can be connected to other 100M network devices.
- 10M/100M self-adaptive network transmission.
- Support maximum 48kHz sampling rate and 16Bit sampling.
- With low power consumption design.
- Adjust the input sensitivity.
- Can customize the network protocol interface.

2.1.1 Installation of Telephone Paging Module

The telephone paging module can be installed on the expansion card slot of the network public address system host with 2 screws.

2.1.2 Telephone Paging Module Settings on the Host

When expanding the telephone paging module in the network public address system, first install and connect the module, and then set the corresponding IP address for the module on the host. After the IP address is set, the module can be connected to the host. Then set the parameters. The setting method is: enter the “Device Management” operation interface, double-click the phone paging card or click the “Edit” button, check the “Terminal ID”, “Version”, “Terminal Type” and “IP Address” of the device in the interface as shown below; you can set parameters such as “Terminal Name”, “Transit Server” and “Channel Control”, and then click the “Save” button in the lower right corner to take effect. After adding a phone number, you can make calls from your mobile phone.



Add Telephone: Select the corresponding channel, then add the called extension number or telephone number.

Telephone Settings: Used to modify the extension number or telephone number bound to the selected channel.

Delete Telephone: Delete the extension number or telephone number bound to the selected channel.

Password Settings: Mainly for incoming calls. After setting a password and enabling password verification, the system requires entering the password before answering an incoming call. (Password must be less than 7 digits.)

Specific Device: When a specific device is selected, there is no need to enter the device number. (If a zone device is selected, the device number must be entered to make the call.)

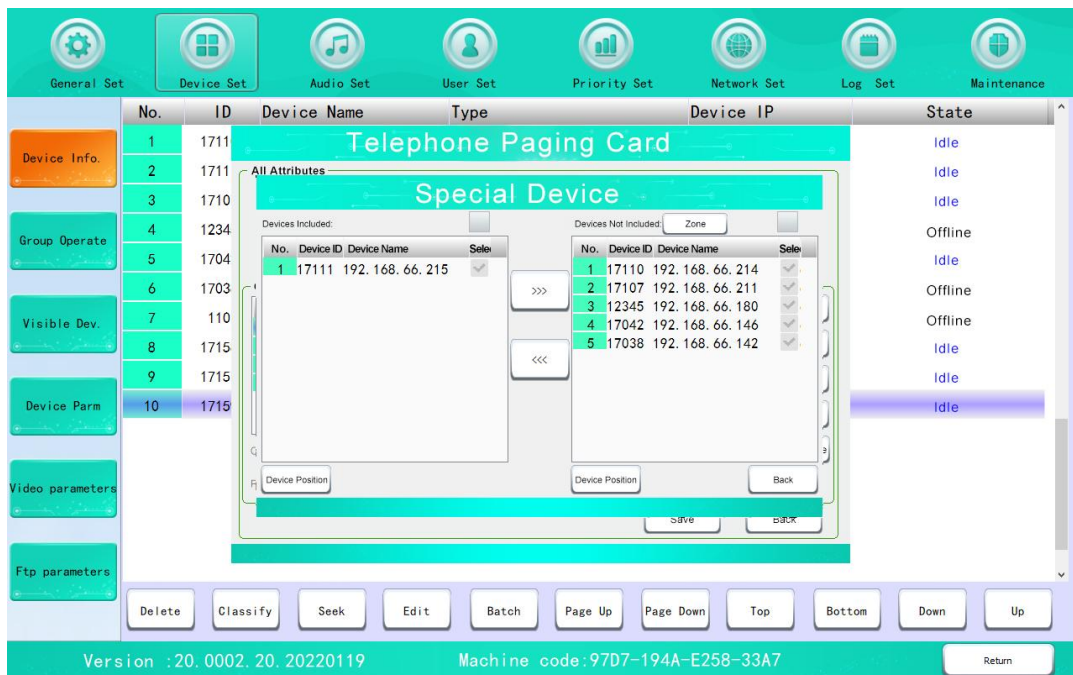

2.2 4-channel Audio Collection Module

The 4-channel audio collection module is a network full-digital analog-to-digital conversion signal processor based on the TCP/IP transmission protocol. Local programs, background music, and intercom voice signals can be transmitted to the public address system through the local audio input interface to achieve seamless combination with the traditional intercom system, with intelligent control, no need for local control. The module can work properly as long as it has been properly set through the management software. It integrates a built-in pressure limiter to ensure that the speech transmission index is not reduced. No local control is required.

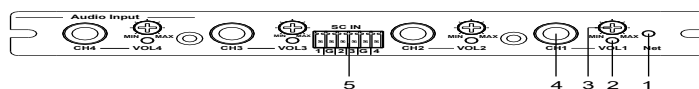

1. Network LED

The indicator light will turn red when the machine is disconnected, and the indicator light will turn green when it is successfully connected to the host through the network.

2. Audio LED

There are four audio indicator lights from right to left. The level of the channel input audio source signal determines the brightness of the corresponding indicator lights.

3. Input Level Control

Adjust this knob according to the level of the input audio source signal.

4. Audio Input Interface

There are four audio channels from right to left (CH1-CH4) for connecting other devices (such as DVD player, etc.)

5. 4-channel SC Short Circuit Inputs

4-channel SC short-circuit signal inputs, which can input trigger signals from other devices to the machine.

Features:

- Modular design, each module can input 4 channels of audio at the same time.
- Convert analog audio signals into digital audio signals, and send them to the network according to the host's requirements.
- Fully digital design, high fidelity, high STI.
- With 4-channel SC short-circuit signal inputs, which can input trigger signals from other devices to the machine.
- With channel partition binding and automatic broadcast function;
- With channel source priority adjustment function;

The 4-channel audio collection module can be installed on the expansion card slot of the network public address system host with 2 screws.

2.2.1 4-channel Audio Collection Module Settings on the Host

When expanding the 4-channel audio collection module in the network public address system, first connect the module to the network where the host is located (please refer to the user manual of the host), and then set the parameters. The setting method is: enter the “Device Management” operation interface, double-click the audio collection card or click the “Edit” button, check the basic information of the device in the interface as shown below; in the idle state, you can set the “Terminal Name”, “Transit Server” switch and “Channel Control”.

1. In the “Channel Control” column, you can modify the name of the four channels, set the source priority (1-10), control the volume of the channel and bind the broadcast partition;
2. When the automatic collection and broadcast function is enabled, each channel can be bound to the zone that needs automatic collection and broadcast, and set the delay trigger off time to 6-60s, and click the “Save” button in the lower right corner to take effect. If the zone is in the state of automatic collection and broadcast function enabled, and set to 6s in delay trigger off time, when the channel has audio input, the bound zone will automatically collect and play the audio. After the audio playback is completed, it will delay for 6s and then close the automatic collection and broadcast function. The collection and broadcast files and the collection log can be viewed in the "Audio Collection Card Log" below.



2.3 Monitor Module



1. Network LED

The indicator light will turn green when the machine is disconnected, and the indicator light will turn red when it is successfully connected to the host through the network.

2. Input Level Control

Adjust this knob according to the level of the input audio source signal.

3. Audio LED

The level of the channel input audio source signal determines the brightness of the corresponding indicator.

4. Amplifier Interface

Connected to a passive speaker and other devices (constant resistance $4\ \Omega/10W$ or constant resistance $8\ \Omega/5W$).

5. Audio Line Signal Input Interface

This interface is used to connect other audio source devices, such as CD, tuner, MP3 and other players.

6. Audio Line Signal Output Interface

Output audio line signals, which can be connected to amplifiers, mixers and other devices.

7. SETUP Port

When the parameters of this module cannot be found, and if the IP is not clear, as long as there's a short circuit in SETUP port, the indicator light will be on, and the parameters of this machine will be restored to the following specific parameters:

IP: 192.168.18.2 GATE: 192.168.18.1

Mask Code: 255.255.255.0

Main server IP: 192.168.18.250 Standby server IP: 192.168.18.251

8. MIC IN

This interface can be connected to other audio source devices, and the input signal is mixed with the signal of the emergency microphone channel input (EMC MIC) on the front panel into the same input channel. When the emergency microphone channel is opened (for local paging), and this interface is also selected at the same time, it will be output together with the signal of the emergency microphone channel. When the emergency microphone channel is closed (cancel local paging), the signal of this interface will not be output.

9. Headphone Jack

Connected to the headphone jack.

10. DIP LED

When the user use the DIP switch to change the IP address, the indicator light will be on.

Features:

- Network monitor function.
- Can monitor terminal output sound.
- Can monitor terminal environment sound.
- With 1-channel line input and 1-channel MIC input function.
- With 3.5 headphone output interface.

The monitor module can be installed on the expansion card slot of the network public address system host with 2 screws.

2.3.1 Monitor Module Settings on the Host

When expanding the monitor module in the network public address system, first install and connect the module, and then set the corresponding IP address for the module on the host. After the IP address is set, the module can be connected to the host.

When the device is in the idle state and the automatic collection and broadcast function is enabled, each channel can be bound to the zone that needs automatic collection and broadcast, and click the “Save” button in the lower right corner after setting to take effect. If the zone is in the state of automatic collection and broadcast function enabled, when the channel has audio input, the bound zone will automatically collect and play the audio. After the audio playback is completed, it will delay for 6s and then close the automatic collection and broadcast function.

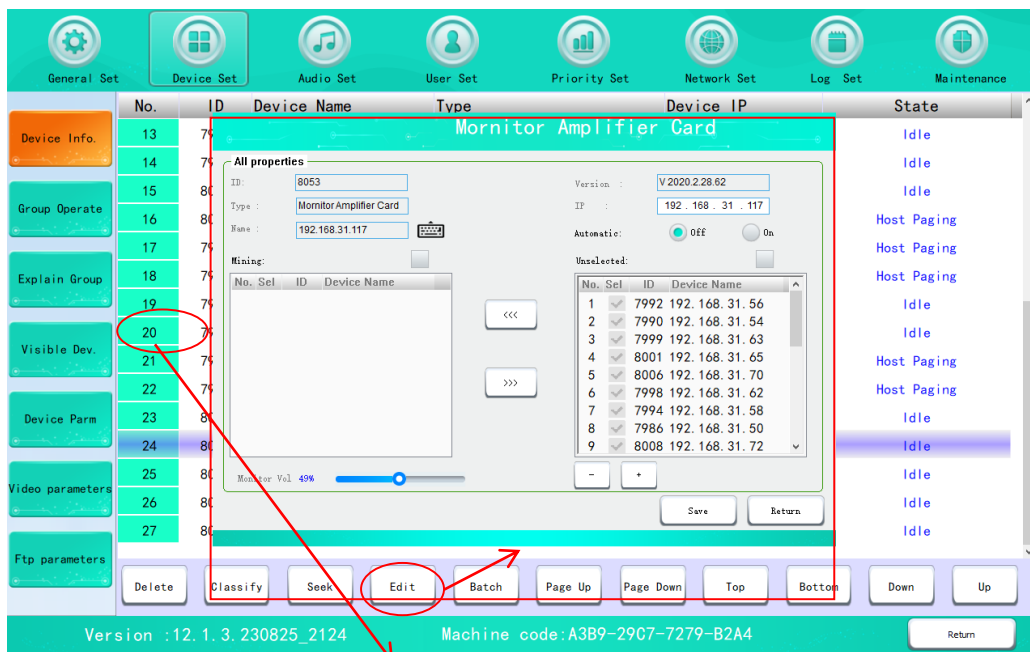

2.4 Hard Disk Module (Only the USB interface is available, other functions are built-in)



1. USB Port

When copying programs to the system, this interface is used to connect storage devices such as USB flash disk or mobile hard disk; when performing system settings and other operations, this interface is used to connect a keyboard or mouse with a USB plug.

Features:

- Record system paging, intercom and other audio files.
- Record video broadcast content files.

2.5 Main Power Expansion Module

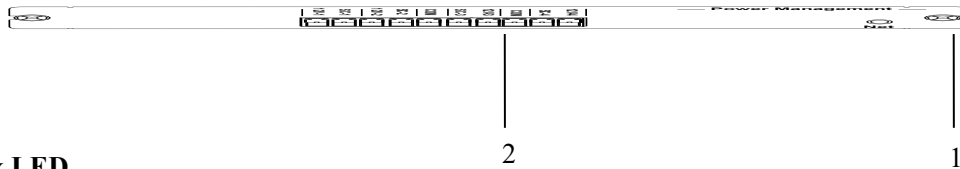

1. Network LED

The indicator light will turn green when the machine is disconnected, and the indicator light will turn red when it is successfully connected to the host through the network.

2. 12V Power and SC Short Circuit Channel

(1) 12V power output interface

12V-1 12V-4, channel 1 to channel 4 are 12V power output, and COM is the common port.

(2) Short circuit signal output interface

SC-1 SC-4, channel 1 to channel 4 are short circuit output, and COM is the common port.

Features:

- With host intelligent power management function.
- With the host switch power management function.
- With the output indication function of emergency events such as alarms and faults.
- With 12V/100mA and SC output, used with the output indicator light.

The main power expansion module can be installed on the expansion card slot of the network public address system host with 2 screws.

2.5.1 Main Power Expansion Module Settings on the Host

When expanding the main power expansion module in the network public address system, first install and connect the module, and then set the corresponding IP address for the module on the host. After the IP address is set, the module can be connected to the host. Then set the parameters. The operation steps are as shown in the figure below:

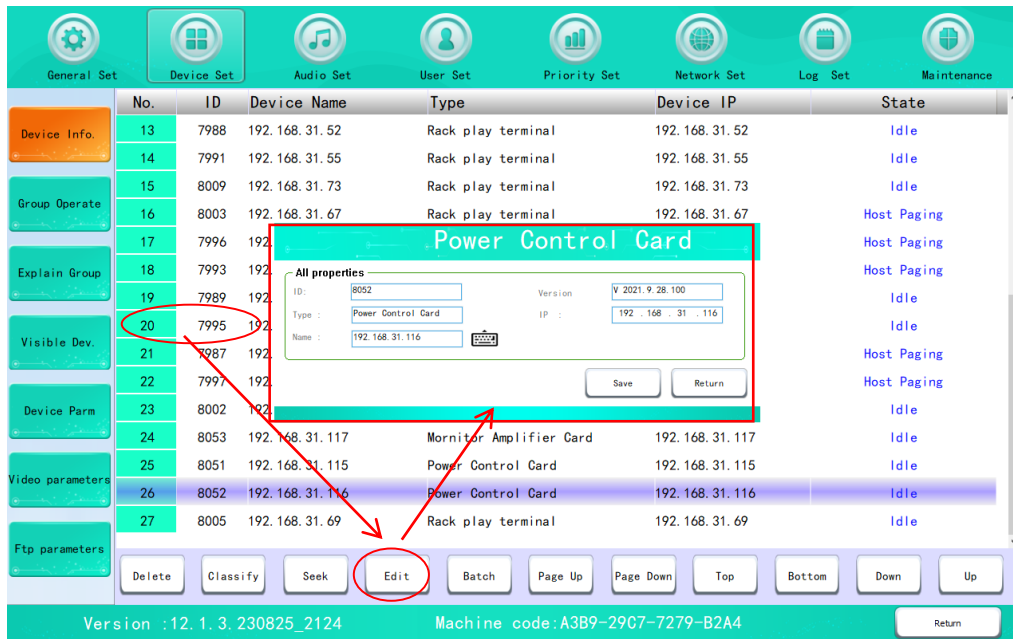

2.6 Standby Power Expansion Module

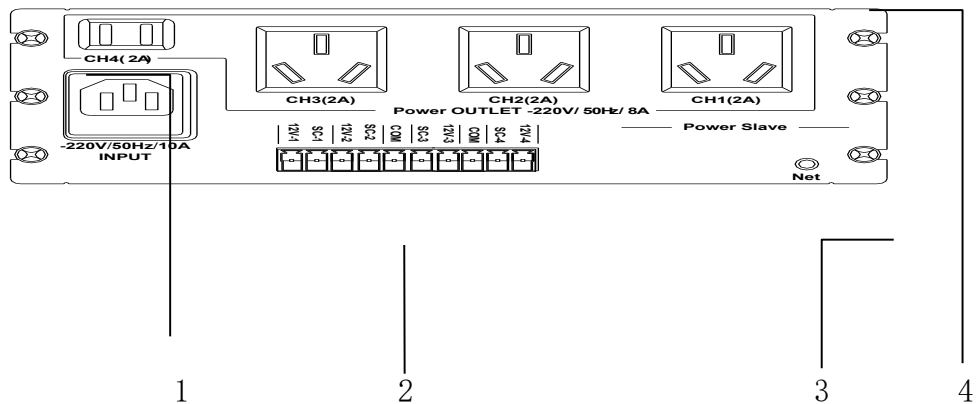

1. Power Sequence Input Socket

The power supply of this card is AC220V ($\pm 10\%$). Please make sure that the voltage value of the power input to this machine is consistent with that of this machine.

2. 12V Power Output Interface/SC Signal Output Interface

12V-1 12V-4, channel 1 to channel 4 are 12V power output, and COM is the common port. The signal output from this interface is controlled by the host, and each channel control corresponds to the corresponding host power control.

SC-1 SC-4, channel 1 to channel 4 are short circuit output, and COM is the common port. The signal output from this interface is controlled by the host, and each channel control corresponds to the corresponding host

power control.

3. Network LED

The indicator light will turn green when the machine is disconnected, and the indicator light will turn red when it is successfully connected to the host through the network.

4. Power Sequence Output Socket

This card comes with 4 time sequence power output sockets for powering other devices. The power supply of this interface can be controlled by the timing point to switch on and off, and it will automatically turn on or off with the arrival of the timing point in the “Program control” state.

Features:

- With host intelligent power management function.
- With the host switch power management function.
- With the output indication function of emergency events such as alarms and faults.
- With 12V/100mA and SC output, used with the output indicator light.
- With integrated 4-channel power output control function.

2.6.1 Standby Power Expansion Module Settings on the Host

When expanding the standby power expansion module in the network public address system, first install and connect the module, and then set the corresponding IP address for the module on the host. After the IP address is set, the module can be connected to the host. Then set the parameters. The operation steps are as shown in the figure below:

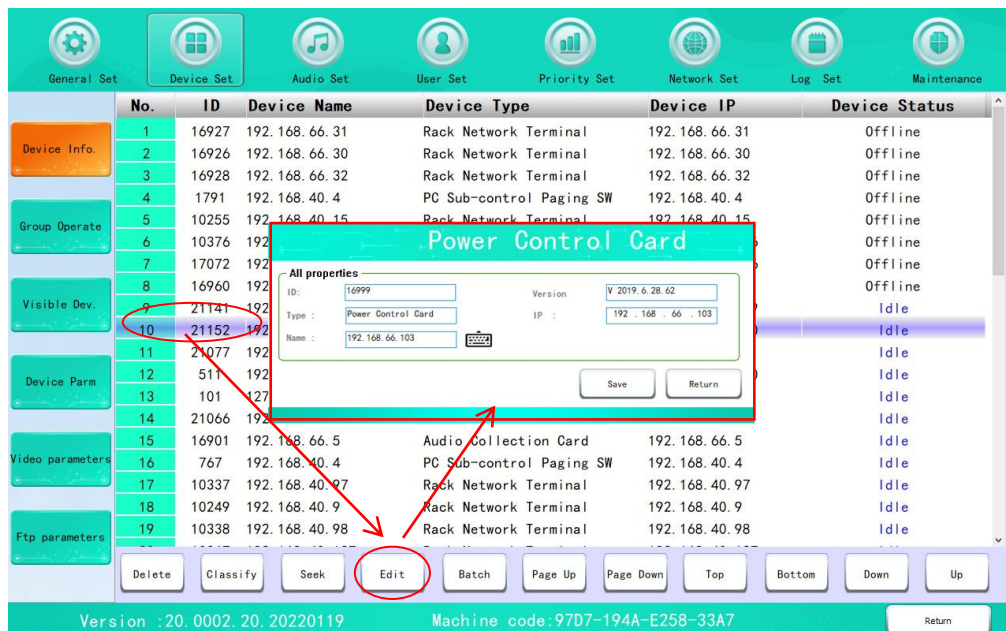

The standby power expansion module can be installed on the expansion card slot of the network public address system host with 2 screws.

2.7 Switch Module

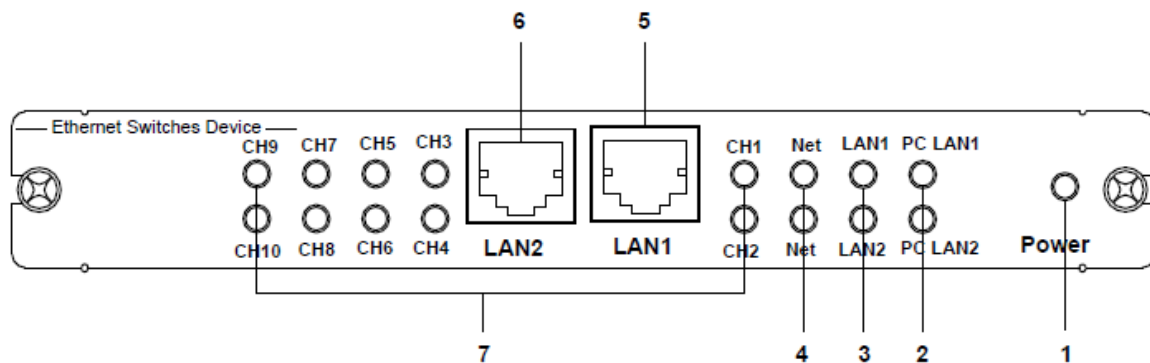

1. Power LED

The indicator light is always on when the power is on.

2. PC LAN LED

The indicator light is always on or flashing when the network connection between the internal motherboard of the host and the switch module is normal.

3. LAN LED

The indicator lights for the connection of LAN1 and LAN2 and the external network, which is always on or flashing when the external network is connected normally.

4. Network LED

The switch module's own network connection indicator, which is always on or flashing when the switch module is working normally.

5. LAN1

Connect the host and the external network 1.

6. LAN2

Connect the host and the external network 2.

7. CH1-CH10 Zone LED

The indicator lights for the network connection of CH1-CH10 and the switch module, the corresponding zone indicator is always on or flashing when the CH1-CH10 is connected to the switch module network.

Features:

- Network data switch amplifier, connected to the host expansion card for network data interaction.
- Bandwidth requirement: 100Mbps/1000Mbps.
- With dual backup amplifier, one of the switch board cards can be replaced by a standby board card if it is broken.

2.8 32-channel Fire Linkage Network Module

2.8.1 Features

- This module is the interface between the network public address system and the fire control center.
- When receiving the alarm signal from the fire center, it will automatically activate the corresponding working area of the network public address system to enter the overridden emergency broadcast state.
- Each machine has 32 fire trigger channels. Through the host settings, the alarm zones of each channel can be combined arbitrarily.
- Each alarm channel includes a path-finding fault detection function to automatically troubleshoot system line faults.
- The same system can have multiple machines connected to the network, and the control area can be expanded arbitrarily.

2.8.2 Appearance Description

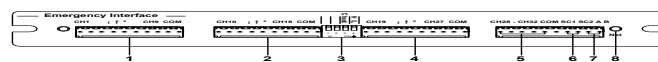

1. Alarm Signal Input Interface

CH1-CH9, channel 1 to channel 9 are alarm signal input port, and COM is the common port.

2. Alarm Signal Input Interface

CH10-CH18, channel 10 to channel 18 are alarm signal input port, and COM is the common port.

3. DIP Switch

Check: Line detection enable switch. This machine has a 32-channel line fault detection function. Press down this switch to turn on the line detection (please refer to the fourth section “The fire channel line detection function settings” for the channel independent switch setting). If you want to use the line detection, you need to configure a 47K pull-down resistor box for the channel that needs to open the line detection.

Note: When the beeping sound of this module is relatively long, it means that the external line is not connected properly. When the beeping sound is relatively rapid, it means that it is an alarm sound.

H/L: When the input logic setting switch is set to H, it is level trigger mode; when set to L, it is short circuit trigger mode.

4. Alarm Signal Input Interface

CH19-CH27, channel 19 to channel 27 are alarm signal input port, and COM is the common port.

5. Alarm Signal Input Interface

CH28-CH32, channel 28 to channel 32 are alarm signal input port, and COM is the common port.

Note: The alarm signal input interface can input a positive polarity signal of 5V-24 V or a short-circuit signal of 0Ω-5K resistance.

6. SC1, SC2 Short Circuit Output

As long as there is an alarm signal input (any one or more channels), SC1 and SC2 are short-circuit output.

7. 485 Communication Interface

A and B are RS485 communication interfaces, which can be used to communicate with other third-party systems to achieve alarm triggering (you need to contact our company's technical staff to use this function).

485 protocol format:

Frame header + Source address + Destination address + Frame number + Length + Function code + Data + Check code

Frame header: FE FC

The source address, destination address, frame number, function code are 1 byte each, the length and check code are two bytes each, of which the high byte is first, and the length does not include the frame header.

The generator polynomial of CRC check is: $X^{16}+X^{15}+X^2+1$

The address of this alarm card is: 0xFE

The meaning of function code:

0x66 Set all zone alarms, followed by 32 bytes of data, of which data 0 means alarm cancellation, 1 means alarm.

0x67 Set a single zone alarm, followed by one byte of channel number and one byte of status data, of which channel number 0-31 indicates channel 1-32, and the alarm status value is the same as above.

8. Network LED

The indicator light will turn green when the module is disconnected, and the indicator light will turn red when it is successfully connected to the host through the network.

2.8.3 This Module Settings on the Host

When expanding the 32-channel fire linkage network module in the network public address system, first install and connect the module, and then set the corresponding IP address for the module on the host. After the IP address is set, the module can be connected to the host.

In the idle state of the device, you can set the "Version Name"; and you can choose either the parallel or alternate mode for fire linkage.

- Parallel Mode: Maintain the normal settings; and simply follow the steps below to operate.

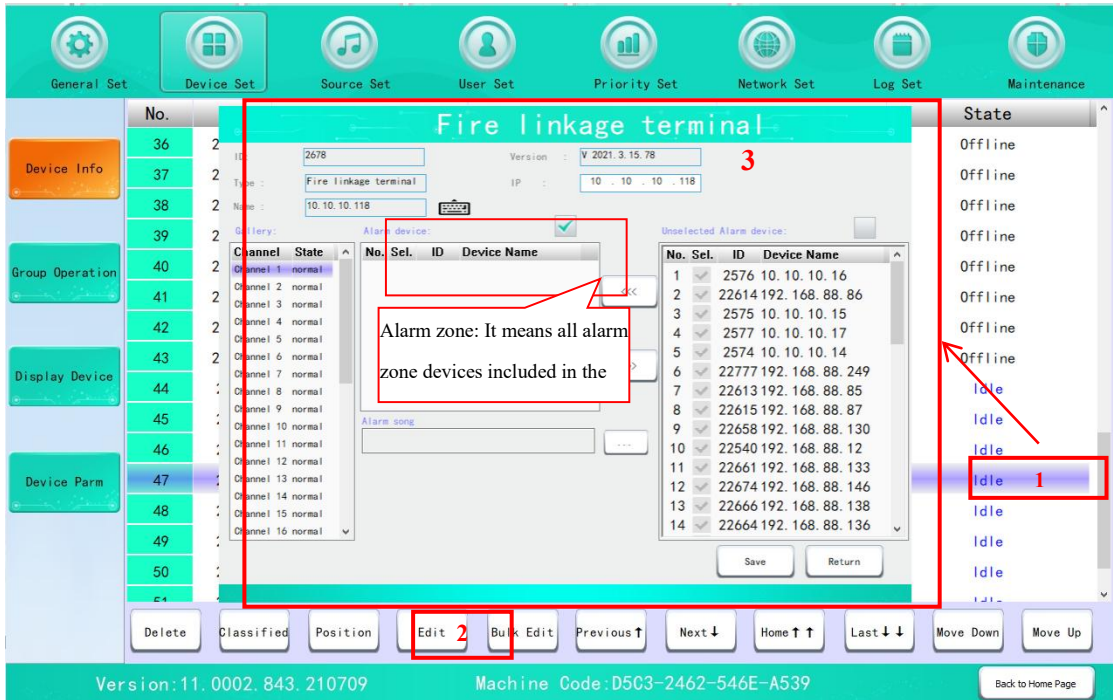

If you need to modify the IP address of this module, you need to enter the corresponding IP (password: 666666) on the browser to change the IP address of this module, and then save changes to modify successfully.

WELCOME

Please enter your login password:

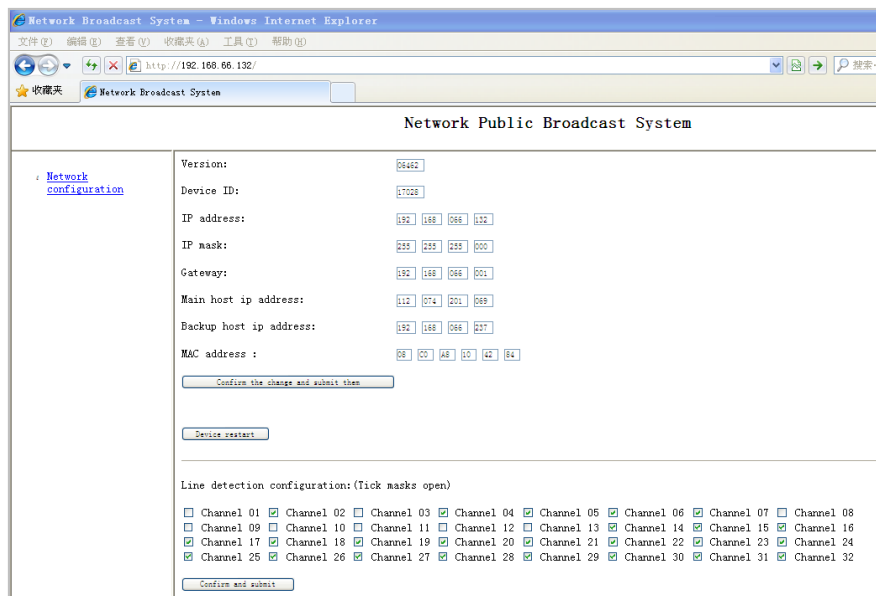

- Alternate Mode: Triggers either a continuous signal or an alternate signal.
- ✓ When a continuous signal is triggered, you can customize the priority setting for broadcast alarm or audio-visual alarm. If broadcast alarm priority is selected, the alarm duration can be set within a range of 10-60 seconds; the same applies to audio-visual alarm priority.
- ✓ When an alternate signal is triggered, the range value can be set within the alternate signal cycle (10-20 seconds), which corresponds to the cycle time of the fire alarm triggering signal. You can customize the priority setting for broadcast alarm or audio-visual alarm. If broadcast alarm priority is selected, the alarm duration can be set within a range of 10-60 seconds; the same applies to audio-visual alarm priority. *(Note: In alternate mode, the alternate signal is only effective when a warning audio file is available. Task interruptions are not recommended in this mode.)*

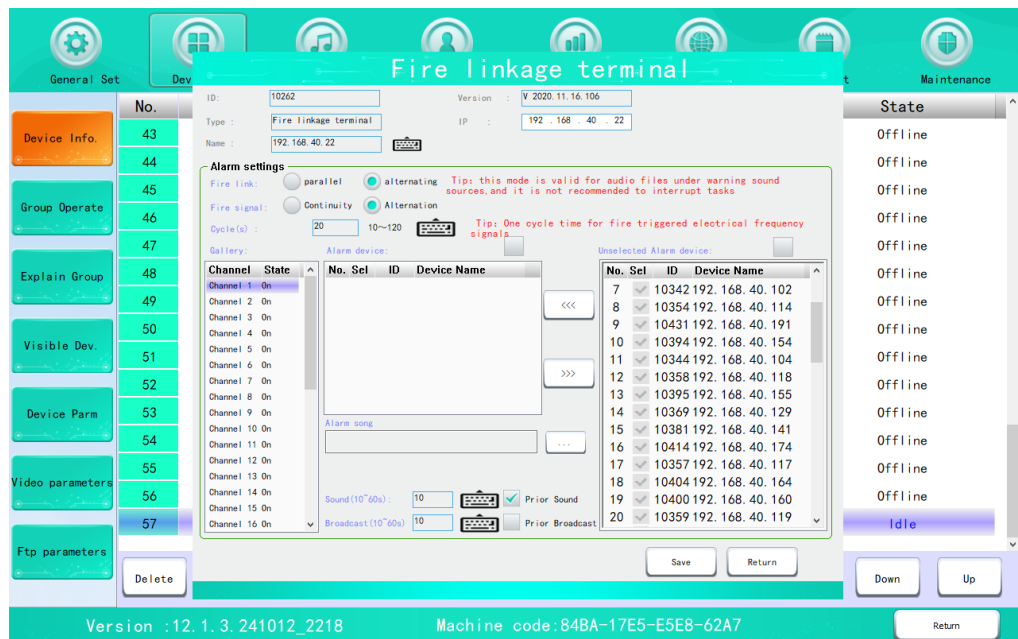

Then, follow the parameter configuration steps as shown in the image. Select a channel from the 32-channel fire linkage module (e.g., "Channel 6" from the channel list). In the "Unselected Warning Zone" list, select a zone and click the "<" button to add it to the "Warning Zone", assigning it to Channel 6.

Next, set the alarm tone for each channel:

1. Select a channel from the channel list.
2. Click the "Edit" button.
3. In the fire alarm tone selection interface, choose the appropriate grouped audio source and corresponding alarm tone.
4. Click "Save" to apply the settings.

Once an alarm signal is received, the assigned warning zone for the corresponding channel will automatically play the selected alarm tone.

2.8.4 Fire Channel Line Detection Function Settings

This module has fire line fault detection function. If you want to use this function, please read this section carefully.

1. If you need to use the line detection, you need to configure a 47K pull-down resistor box for the channel that needs to open the line detection.
2. On the side of this module, dial down the DIP switch of check and turn on the main switch of line detection.
3. In the IE browser, enter the IP address of this module, enter the parameter configuration page, find the line detection configuration, and open the channels that need to use the line detection function.

Line detection configuration: (Tick masks open)

<input type="checkbox"/> Channel 01	<input checked="" type="checkbox"/> Channel 02	<input type="checkbox"/> Channel 03	<input checked="" type="checkbox"/> Channel 04	<input checked="" type="checkbox"/> Channel 05	<input checked="" type="checkbox"/> Channel 06	<input checked="" type="checkbox"/> Channel 07	<input type="checkbox"/> Channel 08
<input type="checkbox"/> Channel 09	<input type="checkbox"/> Channel 10	<input type="checkbox"/> Channel 11	<input type="checkbox"/> Channel 12	<input type="checkbox"/> Channel 13	<input checked="" type="checkbox"/> Channel 14	<input checked="" type="checkbox"/> Channel 15	<input checked="" type="checkbox"/> Channel 16
<input checked="" type="checkbox"/> Channel 17	<input checked="" type="checkbox"/> Channel 18	<input checked="" type="checkbox"/> Channel 19	<input checked="" type="checkbox"/> Channel 20	<input checked="" type="checkbox"/> Channel 21	<input checked="" type="checkbox"/> Channel 22	<input checked="" type="checkbox"/> Channel 23	<input checked="" type="checkbox"/> Channel 24
<input checked="" type="checkbox"/> Channel 25	<input checked="" type="checkbox"/> Channel 26	<input checked="" type="checkbox"/> Channel 27	<input checked="" type="checkbox"/> Channel 28	<input checked="" type="checkbox"/> Channel 29	<input checked="" type="checkbox"/> Channel 30	<input checked="" type="checkbox"/> Channel 31	<input checked="" type="checkbox"/> Channel 32

4. Click OK to enable the line detection function of the corresponding channels.
5. When you need to expand the 32-channel fire linkage module in the network public address system, set the corresponding IP address for the module on the host after installing and connecting the module, enter the host software “Settings” -> “System Maintenance” -> “Device Maintenance”, find the IP address on the label of the 32-channel fire linkage module, select it and click Modify.

III. System Connection Diagram

3.1 Small System Connection Diagram

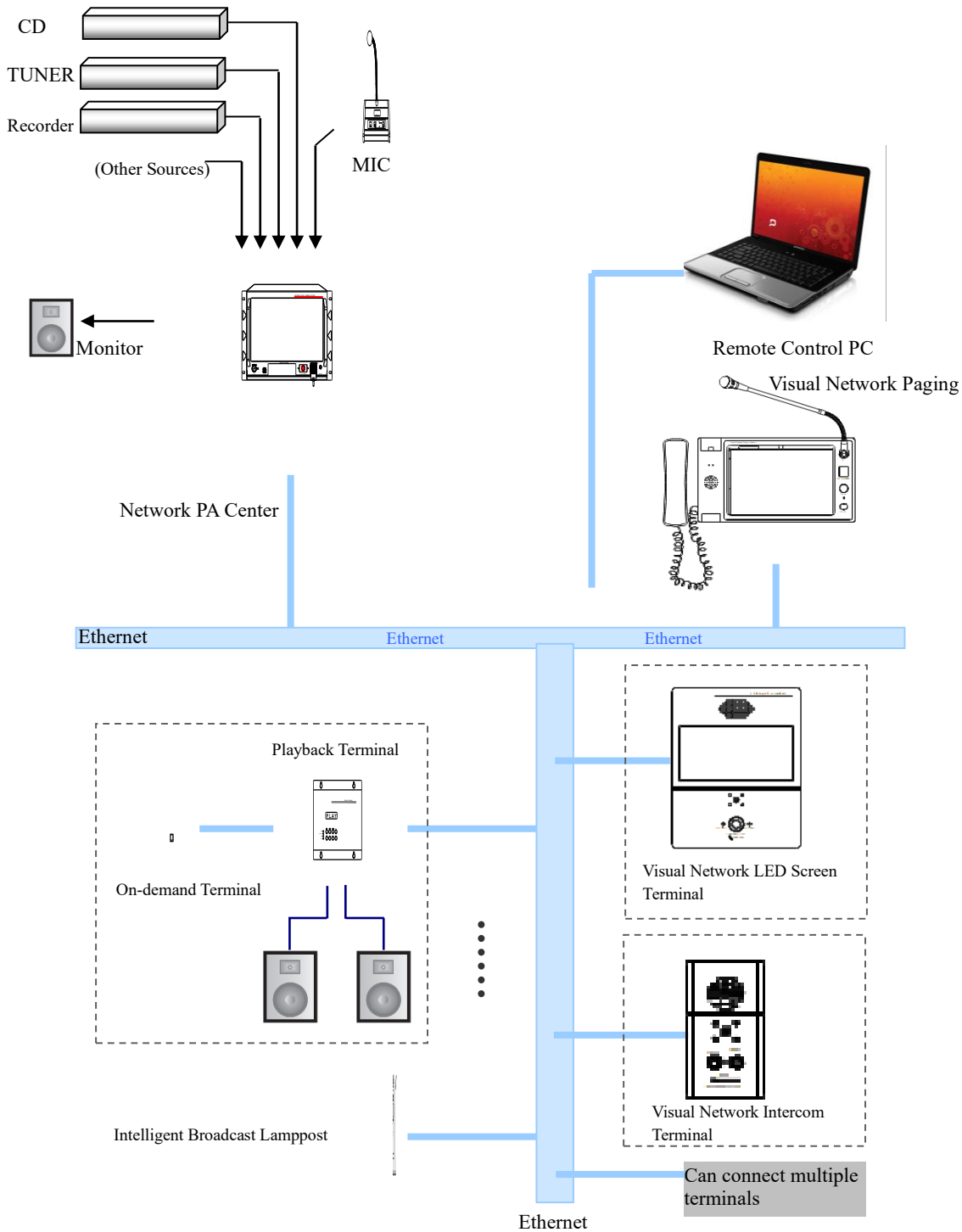

Note:

In the above connection diagram, all devices directly connected to the network must be connected to the network through the switch. And each device connected to the network needs to set a corresponding IP address.

The interfaces of the host and various conventional devices (audio source, microphone, monitor speaker, etc.) are one-to-one correspondence. Please refer to the front panel and rear panel, which will not be repeated here. In order to ensure the rapid transmission of data in the entire local area network, please connect to the network according to the following method (see the above figure (**previous page**)).

It is recommended to set up this system to run on a local area network above 100M (local area network referred to as LAN or Ethernet). When there are fewer broadcast terminals (less than 20 units), it can run on an earlier 10M LAN, but with slightly worse performance. The performance of running on a star structured network is better than that on a bus structured network. It is not recommended to use a hub (HUB) to build the network. (The functions of the hub and the switch are the same, but with much slower speed.)

Generally, the host is first connected to the UPLINK port of the LAN switch (ETHERNET SWITCH), and other ports of the LAN switch can be connected to the broadcast terminal or the UPLINK port of other switches in the LAN. Other switches can be connected to more various broadcast terminals or further connected to the UPLINK ports of more switches. And so on for network port expansion.

The network cables and interfaces frequently used in the LAN are shown in the following figures: (take a 100M LAN for an example. The figure is for reference only, and our company will not provide network devices. If necessary, please consult the network device supplier.)

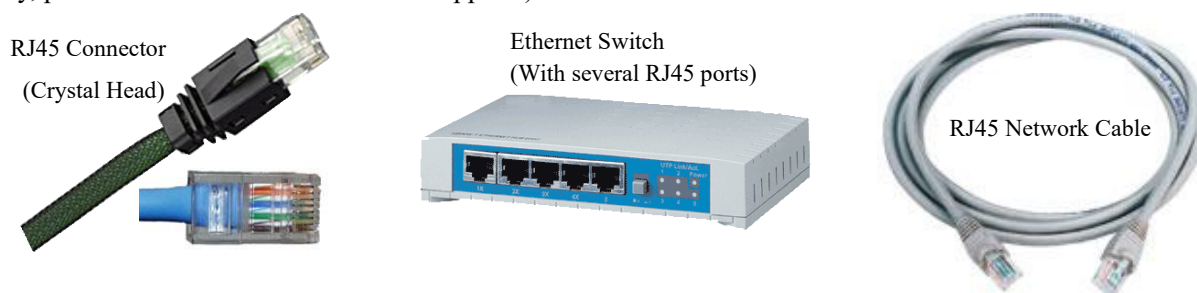

3.2 Small System Features

- The host has built-in 4 audio sources:
 - a. Emergency microphone (EMC MIC) on the panel: Used for general paging, or for temporary release of emergency evacuation command order when encountering a catastrophic accident.
 - b. Built-in chime/alarm (CHIME/ALARM): Used to insert schedule announcement in the program. In the event of a catastrophic accident, press the “All Zone Alarm” or “Zone Alarm” button to issue the preset siren for manual disaster warning.
 - c. Built-in CD (INNER CD) and built-in special sound source: Used as background music.
- The host has four-channel audio input interfaces, which can be connected to four-channel external audio sources as background music.
- The smallest system already has the functions of real-time or regular broadcast of background music, host paging, manual alarm, energy-saving operation in different zones, and can also perform on-demand program or paging on the broadcast terminal.
- Connect to Network playback terminal, which has 30W power output, and a line audio output interface to expand power, and with an optional corresponding on-demand terminal control panel.
- The system uses three kinds of intercom terminals at the same time, including Visual Network LED

Screen Terminal, Visual Network Intercom Terminal, Intelligent Broadcast Lamppost. It has a built-in high-definition camera, supports video intercom, voice intercom, one-key emergency call and other functions, and can be connected to the external surveillance camera for real-time monitoring, and it has a digital power amplifier, expandable power.

- With remote PC control function.
- Can connect network paging controller to achieve remote paging function.
- One system can support unlimited multiple terminal connections.

Tips:

When the broadcast transmission distance is relatively long, you can consider using an Ethernet relay or optical fiber for transmission. When using the optical fiber, you can use an Ethernet switch with an optical end interface, or use a RJ45 interface to optical end interface converter to convert electrical signals to optical signals for transmission. For details, please consult the network device supplier.

3.3 Typical System Connection Diagram

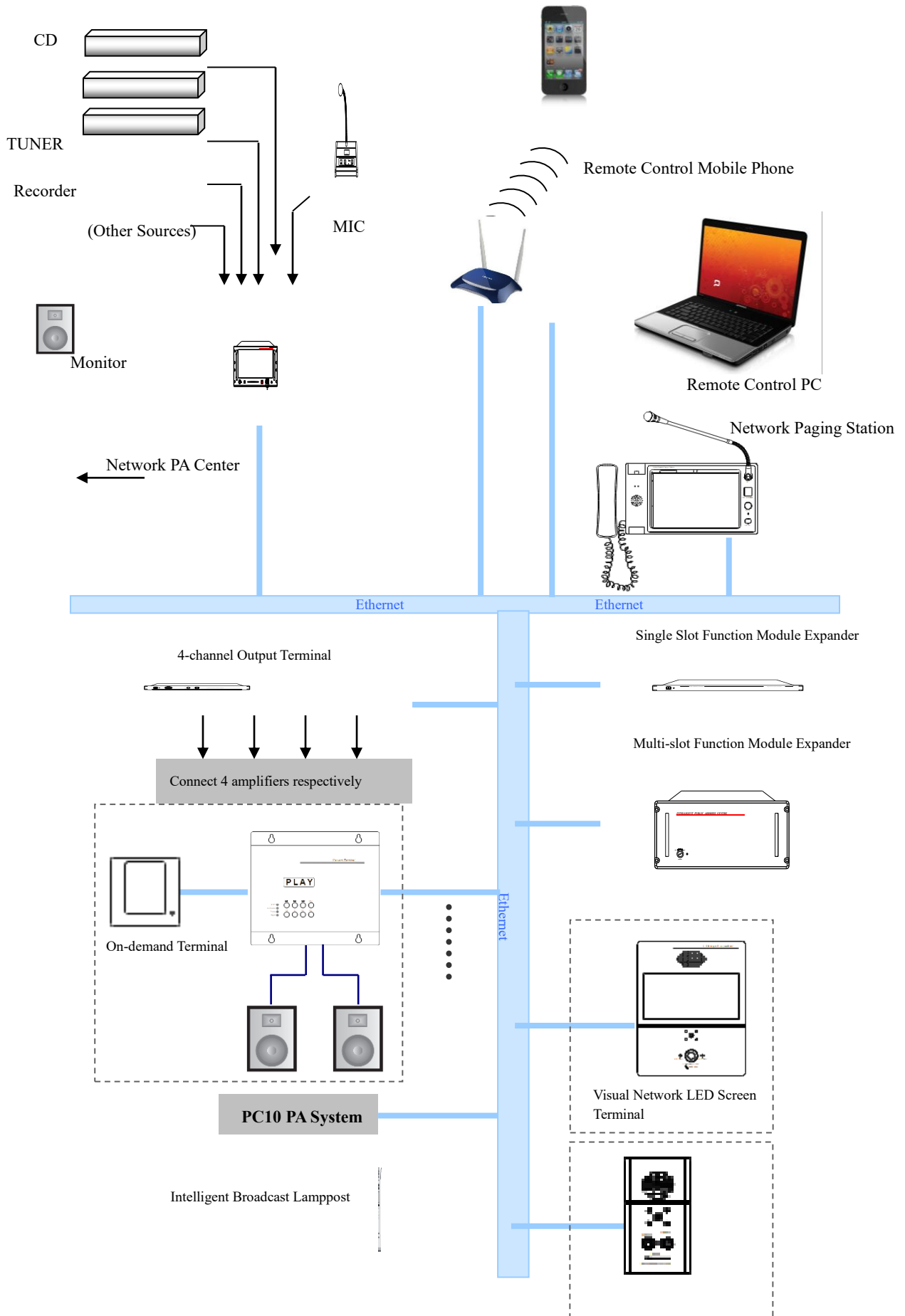

Ethernet

Visual Network Intercom
Terminal

In order to improve the reliability of the system, the host is equipped with a broadcast standby machine, which can be automatically selected by the main/standby switch. During the operation of the system, if the host fails, the standby machine will automatically connect and continue to work. The peripheral devices of the host are all connected to the main/standby switch.

The system is equipped with various broadcast terminals, such as a single-channel player terminal with MP3 player and a 4-channel player terminal without MP3 player, which adds multi-point paging, on-demand program, visual intercom, remote control and other functions to the system.

Other PCs (remote control): Remote control software can be purchased to perform authorized remote control operations on the host of the broadcast center on the user's computer. It can also connect a mobile phone via wireless WIFI to realize mobile phone wireless paging and on-demand operations. For details, please refer to the manual attached to the remote control software.

Module expansion box: The system can expand the audio collection function module and the telephone paging function module, and is equipped with a single-slot module expansion box and a multi-slot module expansion box for installing expansion modules. For specific information, please refer to the manual attached to the expansion box and module.

3.4 Typical System Features

In addition to all the functions of the smallest system, a typical application system also has the following features:

- With 4 output terminals, one device can provide 4 audio output terminals.
- Can realize mobile phone remote paging, zone control, on-demand operation and visual intercom through wireless WIFI.
- Can expand multiple function modules through the single-slot or multi-slot expansion box, such as audio collection function module and telephone paging function module.
- With strong scalability, it can build a wider public address system with PC10 peripheral systems.

IV. Operations and Settings

4.1 System Start-up Process

As shown in the introduction to the front panel of the network public address center, turn on the power of the host by turning the special switch key clockwise. The power indicator flashes yellow when the power is turned on. Because the host of the network public address center is an embedded industrial computer, it needs to do self-test when starting up, and needs to load various drivers. Therefore, the startup time is slightly longer, about 40 seconds. After the startup is complete, the host displays the main interface (as shown in Figure 1), and the power indicator turns green and stops flashing.

Turn on the power of each terminal while starting the host, and the status of each terminal will be displayed on the main interface immediately after the host startup is complete.

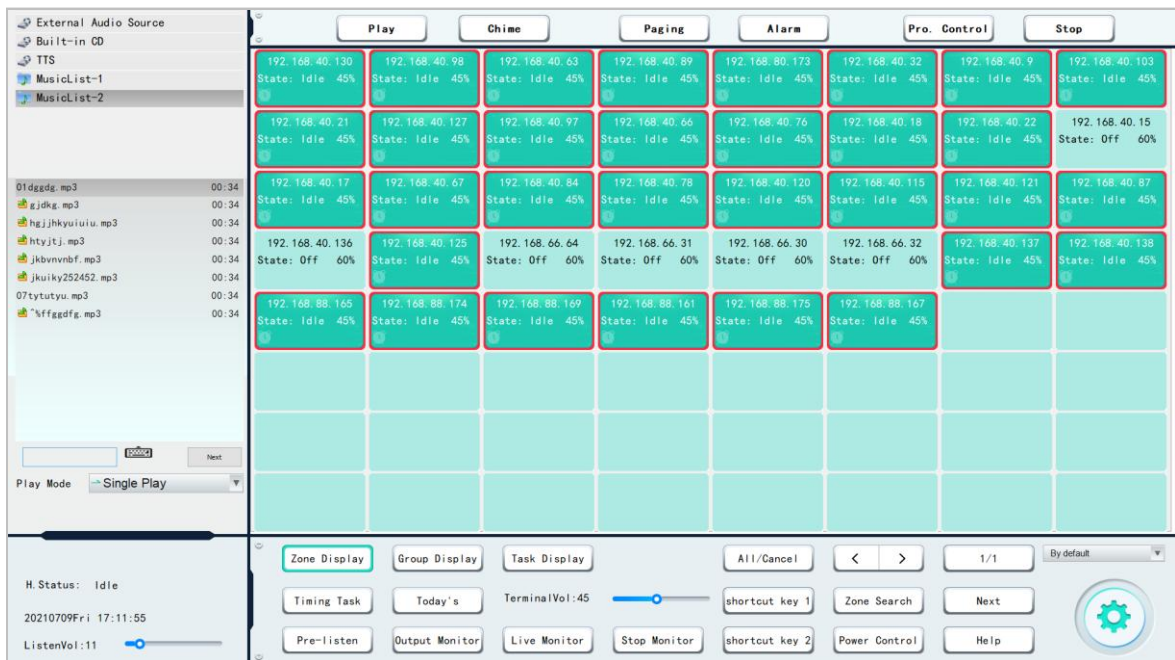

Main Interface

As shown in the figure above, the items listed on the main interface include the zone status, the function items that need to be frequently operated, and the basic status of the system. The functions on the main interface can be divided into three categories:

View system working status: Can view the status information of each zone, view the audio source program type, program content and peripheral power status, etc.

Play programs for a zone: Can play background music for each zone, insert chime, issue paging and fire alarms, perform timing points and other operations, and monitor the playback status of the zone, adjust the volume of the zone, and pre-listen to the program audio source.

Other common manual operations: Control one or more tasks of playing songs, view the geographic location of

the zone and operate the shortcut keys one and two, preview the video of the environment monitored by the terminal and view system time, etc.

4.2 View System Working Status

4.2.1 View Zone Status

As shown in the figure below, click the desired zone button to select the zone, and the zone button will display with a red border. Click the button “/ ” at the bottom of the main interface to view all the zones/groups, and the operations for the groups are the same as the zones (to set the groups, please refer to the “Group Operation” under the “Sound Source Management” directory below); click the button “” to select all zones or cancel all zones, click the button “ ” to scroll left and right to view the zones/groups, click the button

” to manually enter the page number to view the zones/groups of a certain page. Click the icon of “ ” button to pop up the keyboard interface, enter the zone name, and then you can quickly find a certain zone, and if multiple zones are found with the search keyword, you can click the icon “” to choose next zone. If multiple zones are found with the search keyword, you can click the icon of this button to select the next zone. Click the button “” to view the operating instructions of this system. In the interface “”, you can set the zones to be displayed according to device ID, name sorting, etc.

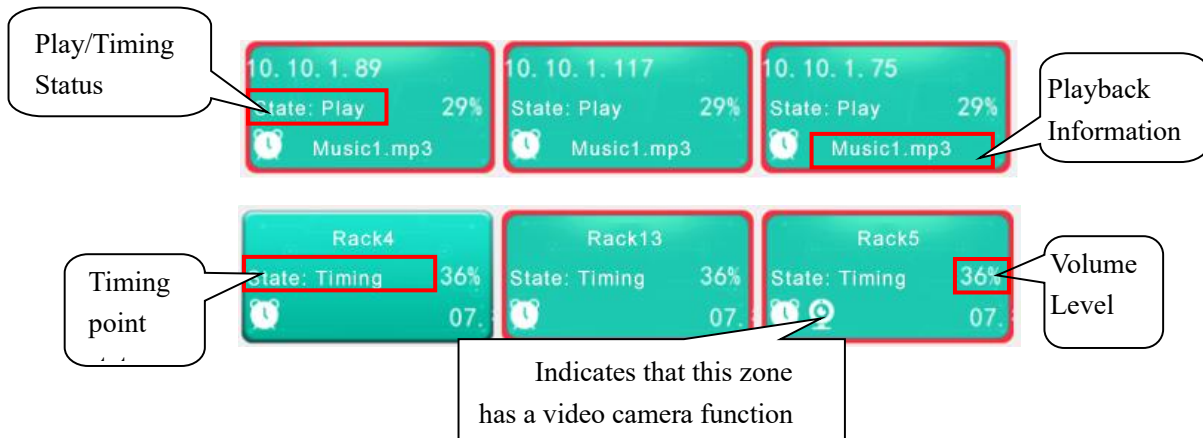

- The top row of each zone shows the zone name (the user can edit the zone name). If the zone status is dark green, it indicates that the terminal of the zone is online, and if light green, it indicates that the terminal is offline or dropped.
- There are two rows of tips below the zone name:
 The first row of text displays the playback information: The program name is displayed when a background music is played; “Paging...” is displayed when there is a paging signal; “Phone access” is displayed when a call is incoming; the chime name is displayed when a chime is inserted; the name of the alarm signal is displayed when the alarm sound is played; the “Alarm card alarming” is displayed when the alarm is issued. The second row of text shows the timing status and zone volume. The timing point status can be “Enabled” or “Disabled”. “Enabled” means that this zone is under timing control, and “Disabled” means that this zone

is under manual control.



In a network public address system, an output terminal will display its functions such as fire alarms and background music. These can be grouped together, and one group can be assigned to different zones in the group.

Tips

After the manual operation of a zone is complete, remember to switch back to the program control state,

audio tasks, (terminals) and on

4.3 Play Programs for a Zone

Before playing the program to a zone, first copy the program to the system and classify the program. This operation is described carefully in the “Sound Source Management” in “System Settings”. Broadcasting programs to a zone includes: playing background music, issuing alarms and emergency broadcasts, inserting chime, paging, etc. Each audio source has a priority output level. The default priority level of this system is as shown in the figure below.

Note: The priority is gradually reduced from 1-8, the higher-level operation function can interrupt the lower-level operation function, and the same level cannot interrupt each other.

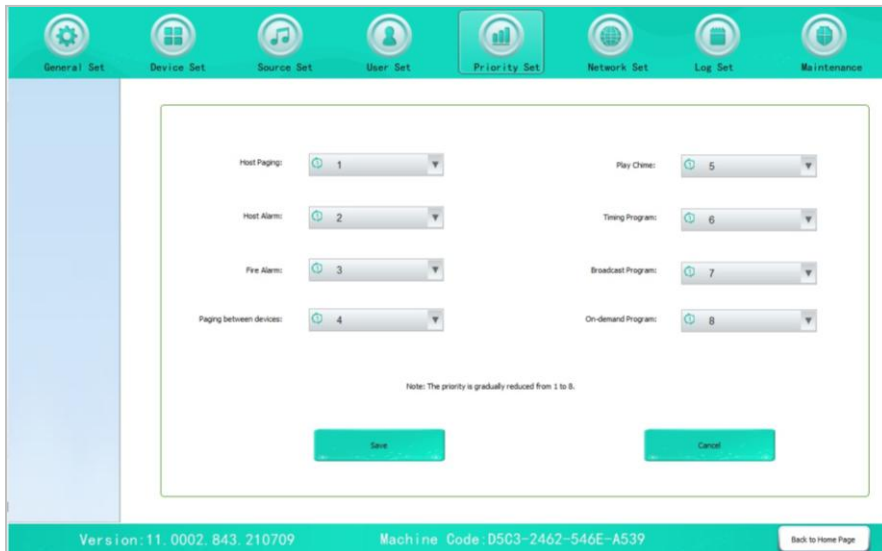

Priority Settings Interface

4.3.1 Edit Program Groups

The steps to edit a program groups are as follows:

Click the "System Settings" button of the main interface to enter the "Sound Source Management" interface, touch

"USB disk songs", insert "USB disk" (There are already downloaded songs on the USB disk), when the prompt word of "USB Ready" appears, you can copy the song to the host, as shown in the following figure:

Step 1: Select the songs you want to copy in the list on the left, and then select the host music directory folder;

Step 2: Tap the button  to successfully copy the songs from the USB flash drive to the specified host music directory folder. In the host songs screen, click the corresponding "Host Music Directory" to see the copied songs under the "Included Music List".

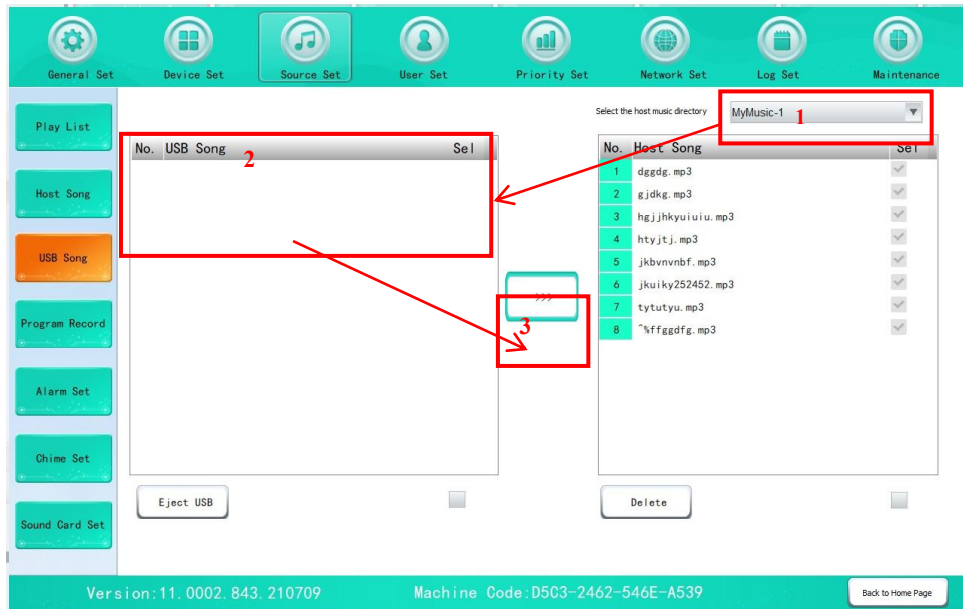

USB Songs Interface

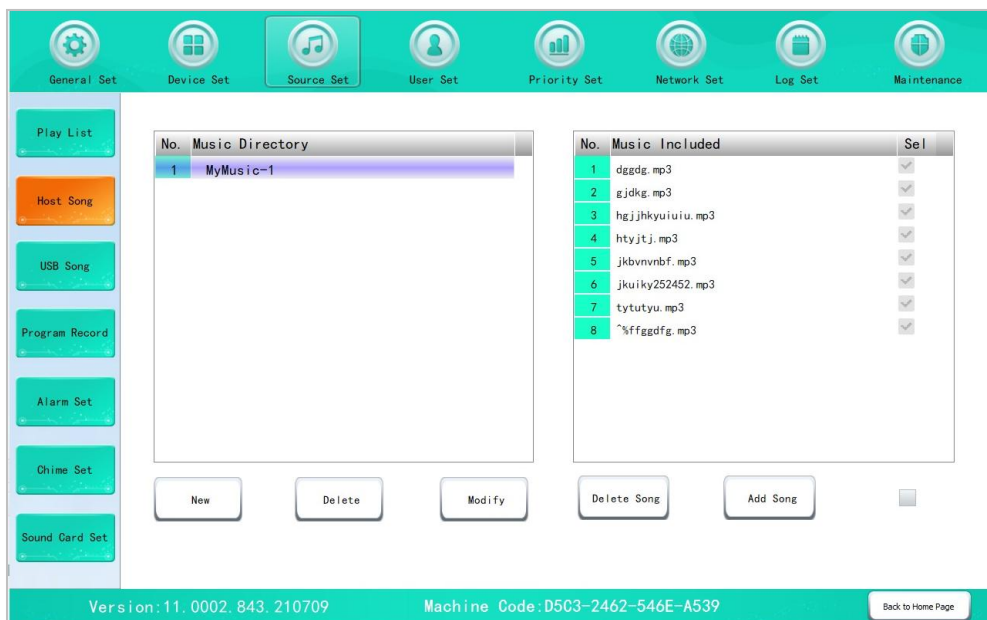

USB Disk Songs Interface

4.3.2 Control PC10 Peripherals Equipment

The Network PA System supports remote control of PC10 series peripherals as follows:

1) Controlling the sequence controller, click the device of display screen, click "control" button, as shown below:

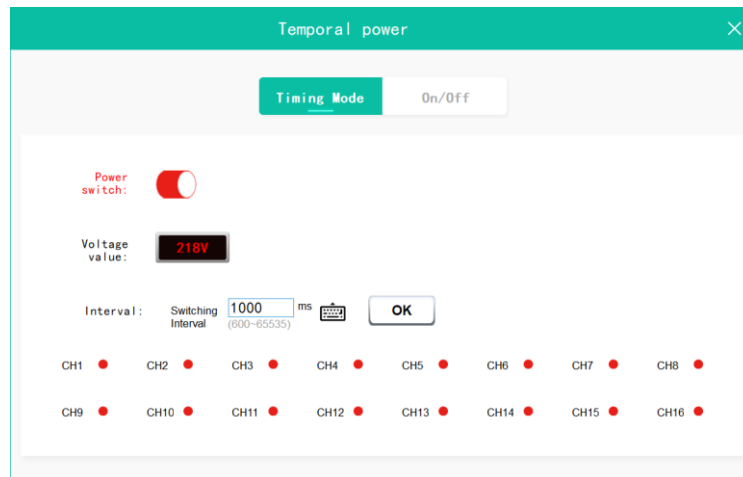

Timing Mode

- The voltage value is displayed as the voltage connected after the power switch is turned on. Click the button “” at the Power Switch, if the button is red, it means that the power of the device is turned on, otherwise, it means that the power of the device is turned off. CH1-CH16 correspond to the 16 power output on the rear panel of the device, which are used to connect other devices.

Note: The power supply of the device has a priority function. When the power of the device is off, the sequence device’s power can be remotely turned on or off on the PC or network host. When the power of device is on, its power cannot be turned off through PC or network host.

- When in “Timing Mode”, please set the switching interval time (time range: 500-65535ms), click “OK” button, and after turning on the power, the machine will turn on 16-channel power supplies in sequence, the 16 lights will turn on red lights in sequence; after turning off the power, the machine will turn off the 16-channel power supply in the reverse order of startup, and the 16-channel indicator lights will turn gray in turn.
- When in “On/Off Mode”, you could turn on or off the power by clicking the “” button of 16-channel power. When the power is on, the indicator light and switch are displayed in red, and when the power is off, the indicator light and switch are displayed in gray.

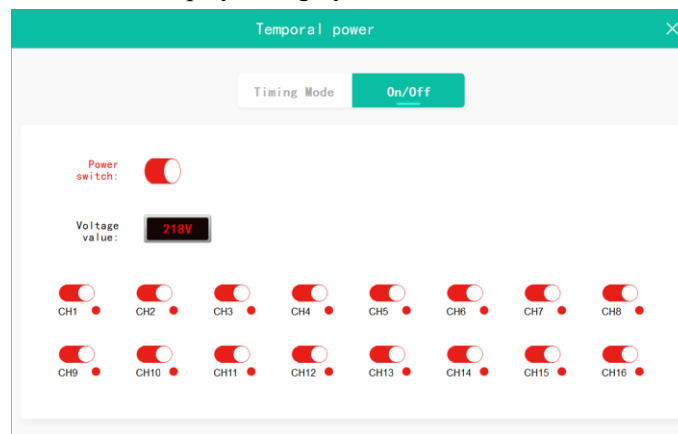

On/Off Mode

2)When controlling the broadcast partitioner device, select the device and click the "Control" button to enter the following interface:

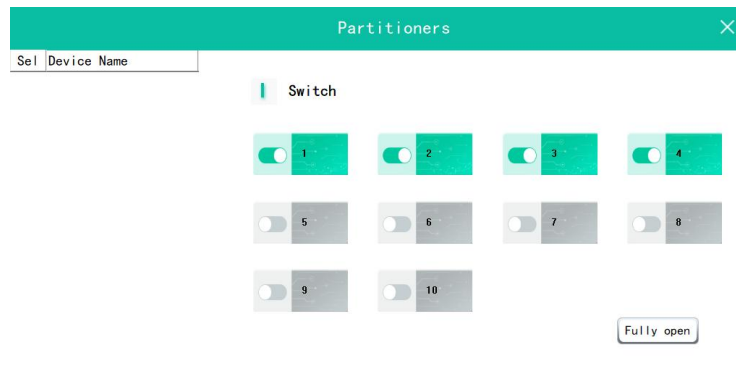

- The 10 channel partitions in the figure in the above figure above respectively represent the 10 channel partitions on the rear panel of the equipment. Click “All On / All Off ” button to fully open or close the 10 channel partition switch.

3)When controlling the pre-amplifier, click the device’s name of list, then click “Control” button to enter the interface as shown in the following figure:



- Slide the volume bar or “+/-” button in the interface to adjust the volume of MIC1-MIC5、AUX1-AUX5, treble and bass or total volume.
- Click the “Chime” button to send out the bell prompt sound.

4)When controlling the AM&FM Tuner, click the device’s name of list, then click “Control” button to enter the interface as shown in the following figure:

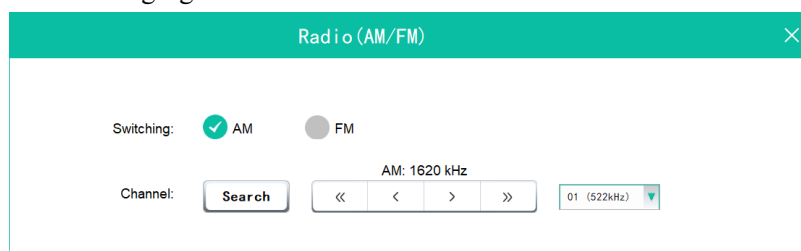

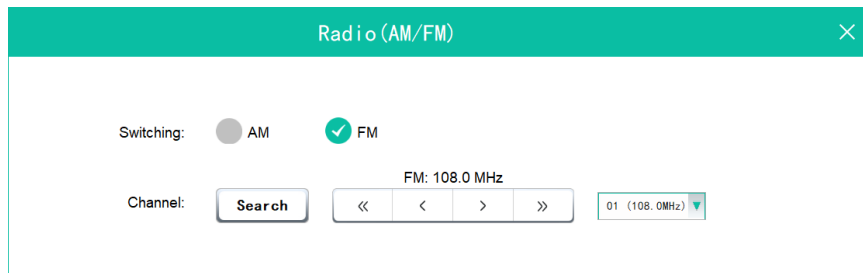

- Select “AM” “FM” to switch AM/FM radio mode. The radio frequency range of FM band is 87.00MHz-108.00MHz, and the radio frequency range of AM band is 522kHz-1620kHz.
- Click the “</>” button to fine-tune up/down, each time you press the button to increase or decrease the receiving frequency by one step (50kHz for one step of FM, 9kHz for one step of AM).
- Click “<</>>” button to search up or search down, it will be automatically stopped when there’s a signal from radio station.
- Click “Auto Search” button, the device can automatically search for radio stations, and the radio stations with signals will be stored in 1-40 memory numbers. If there are more than 40 stations, they will be replaced from the first radio in sequence again. (Eg: The first station will be replaced by the 41st station, and so on.)
- After saving the station, click the inverted triangle button behind the station to play 1-40 radio stations.

5)When controlling the CD/MP3 Player, click the device’s name of list, then click “Control” button to enter the interface as shown in the following figure:

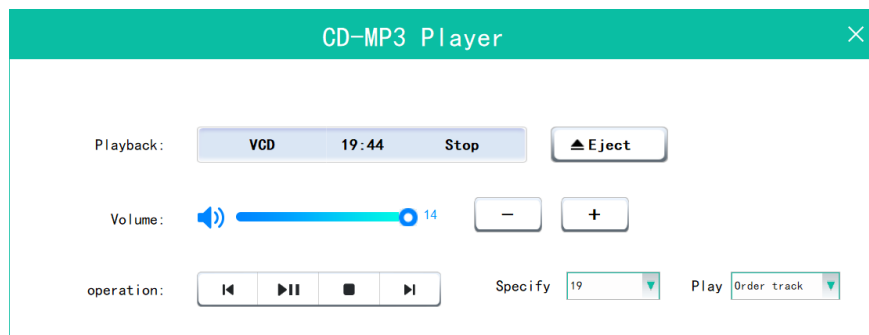

- The left side of display bar **MP3 00:00 停止** shows that the currently playing audio source is MP3, and the middle is the playing time. "Stop" means that the device audio source is in the stop playing state. Click "Eject CD" to eject the disc compartment.
- Slide the volume bar or click “+ -” button to adjust the device’s volume.
- When the music is in playing state, touch “▶||” button to play or pause the music, touch “◀” or “▶” button to directly choose play the previous song or next song.
- When inserting a CD, after the device reads the CD song, it will be displayed behind the "specified track", click to select 1-200 songs to play.
- Touch the "Sequential Play" button in the figure to switch the following four playback modes:
Order Play: it means that all songs of the current read sound source are played in sequence.

List Play: indicates that all songs in the current list are played in a loop.

Single Loop: indicates that the currently selected song is played in a single loop.

All Loop: it means that all songs of the current read sound source are played in a loop.

6) When controlling the Main Standby Amplifier Auto Switcher, click the device's name of list, then click "Control" button to enter the interface as shown in the following figure:

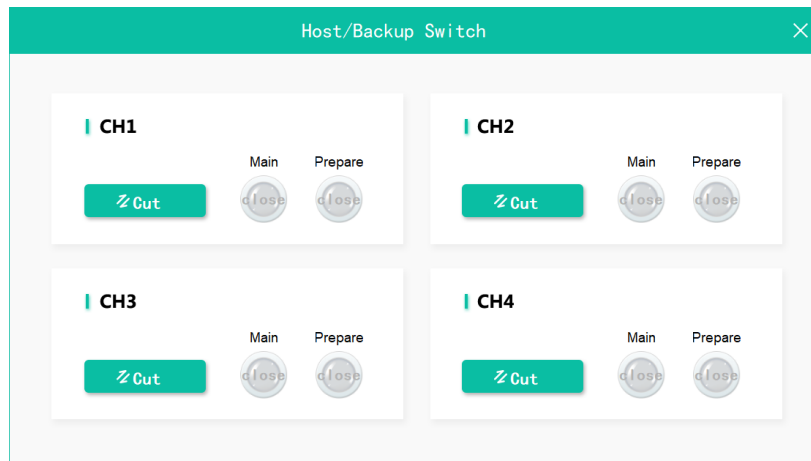

- Each channel has a main power amplifier and a backup power amplifier. Click the "Cut" button of the 4 channels (CH1-CH4) to manually switch between using the main amplifier or the backup amplifier of the current channel; When using the main power amplifier, the main power amplifier is displayed as open, the backup power amplifier is displayed as off, and the button is displayed in red when the power amplifier fails. If the backup power amplifier is calling to used by other faulty power amplifiers, the backup power amplifier will be displayed as ON, and the current channel being used will be displayed on the backup power amplifier button.

4.3.3 Play Programs for a Zone

There are four types of audio sources when playing programs to a zone, including external audio sources, built-in CD audio sources, TTS audio and built-in player audio sources; as shown below:

When playing the external audio source:

Step 1: Select the external audio source in the [audio source selection](#) column. Please make sure that there is an external line audio signal input or the audio collection card has an audio input or streaming media gateway device access.

Note: After accessing the streaming media gateway, the IP name is displayed here for the first time (IP: 192.168.82.139 as shown in the figure). If the IP name is displayed in red, it indicates it is offline. When selecting the network radio of the streaming media gateway or Airplay wireless push for broadcasting, first double-click the streaming media gateway device to enter the interface as shown below, where you can choose "Radio mode" or "Airplay mode", and if you select "Radio mode", you can directly select the corresponding network radio station in the interface, but if you select "Airplay mode", you can select a music player with DLAN function (such as NetEase Cloud Music, Kugou Music, etc.) for wireless push, and make sure that the IOS and Android devices of the push end must be connected to the same network as

the host end.

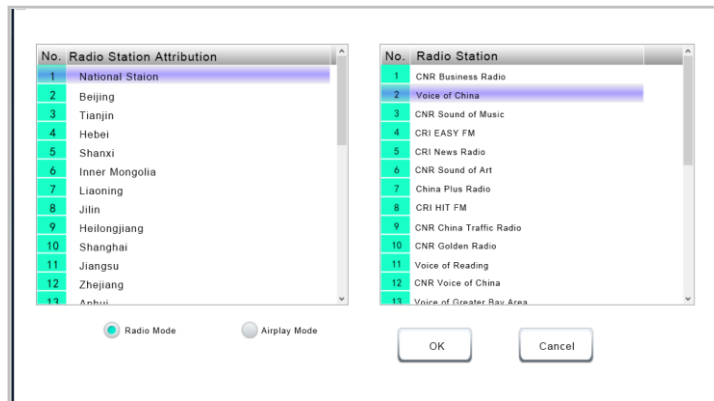

Step 2: In the [zone](#) column ③, directly click the zone that needs to play the program, which supports single or multiple selection, and the zone button turns green when selected.

Step 3: Click “Play” directly in the play bar ④, and then set the play status and play mode in the play mode bar ⑤. The play mode includes five modes: single play, single loop, random play, order play and list play.

When playing the built-in player audio source or the built-in CD audio source:

Step 1: Select the built-in player sound source or the built-in CD audio source in the [audio source selection](#) column ①, and all programs of this type will be displayed in the list box below it. Note: When playing the built-in CD audio source, please first put the CD into the built-in CD tray of the host.

Step 2: Select a certain song or program in the program list ②, you can enter keywords to search for songs or programs. If multiple zones are found with the search keyword, you can click “NEXT” button to select the next song or program.

Step 3: In the zone column ③, directly click the zone that needs to play the program, which supports single or multiple selection, and the zone button turns green and with red frame when selected.

Step 4: Click “Play” directly in the play bar ④, and at the same time, set the play status and play mode in the play mode bar ⑤. The play mode includes five modes: single play, single loop, random play, order play and list play. It will be stopped to play when you click “STOP” button.

Step 5: When playing the audio source of the built-in player, you can click the “Task Display” button in the function operation bar ⑥ below to enter the interface as shown in the figure below. The zone of the task display interface represents the zone of the current playback task, and the playback status of the zone of the current playback task can be set. If selected, the zone is purple. Click the button ⑦ to pause the playback, click the button ⑧ to continue playing; click the button ⑨ or the button ⑩ to switch to the previous or next song, click the “Play” button to play the audio source list on the left, click the “Stop” button to stop the task zone playback.

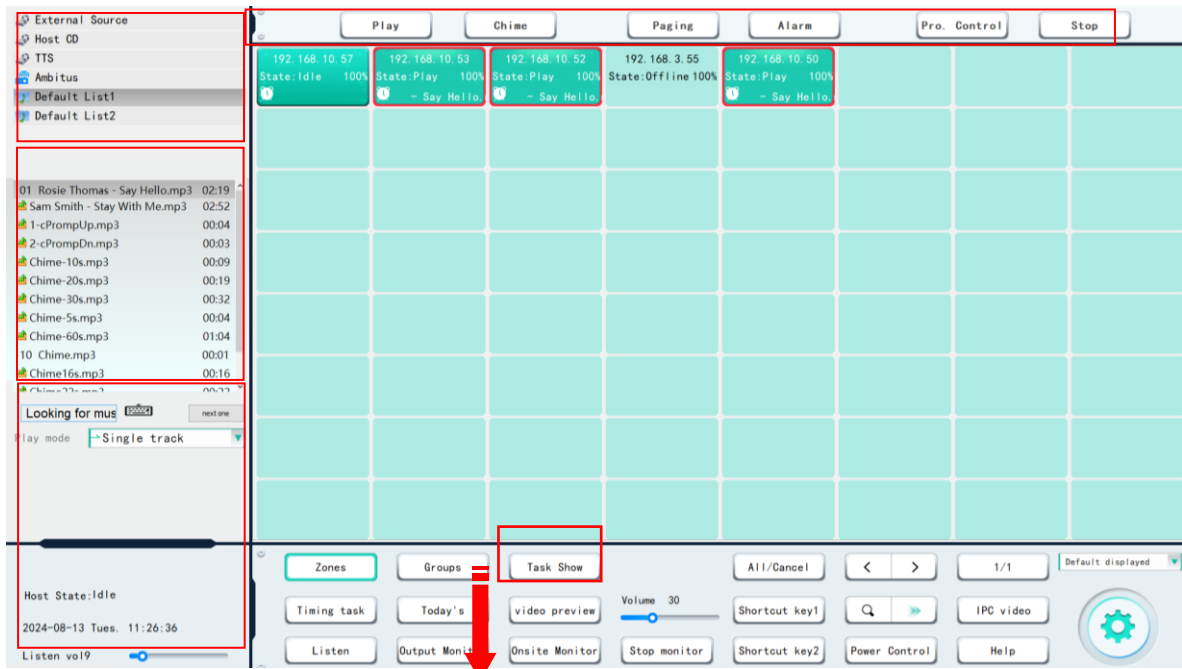

Playback Interface

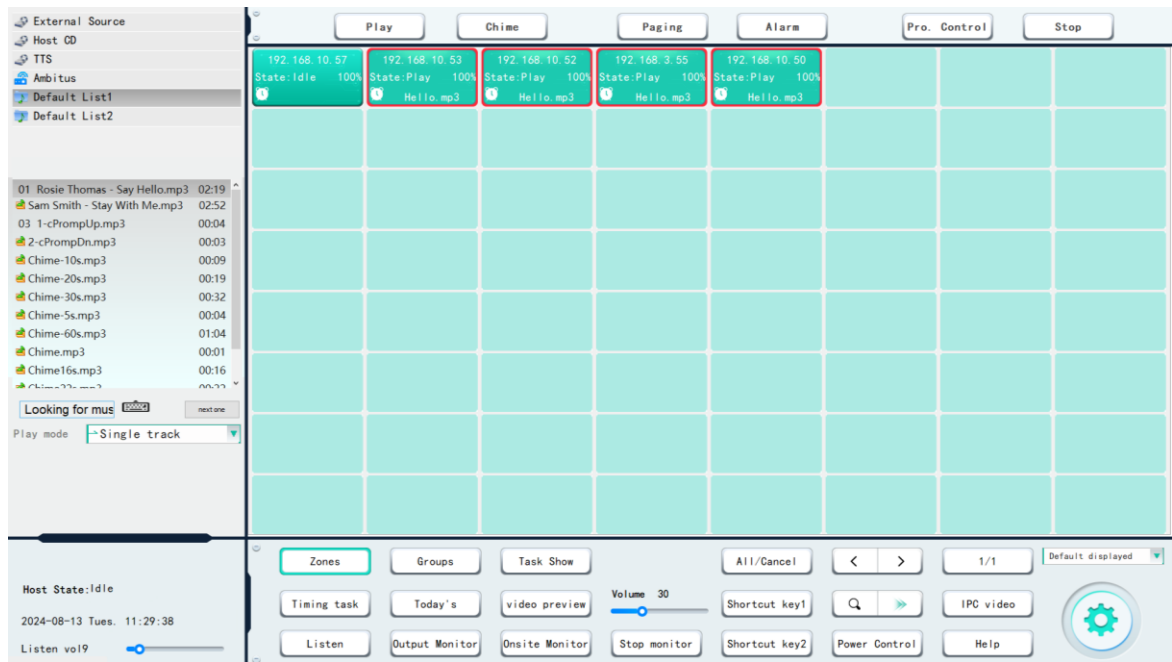

Task Display Interface

When playing the TTS audio source:

Step 1: Select TTS voice in the audio source selection column ①. The TTS voice setting item appears in the ② area. Select the language (Chinese and English), and the pronunciation person (male and female voices), then enter the Chinese and English characters (Up to 500 characters) or select TTS entries, and set the speech speed and the number of playbacks. You can edit the TTS entry in advance. When editing, click the "TTS Entry Edit" button to pop up the edit box as shown below, enter the display name and content (Up to 500 characters) and confirm. At this time, the added entry will be displayed in the TTS entry list or imported

through TXT text.

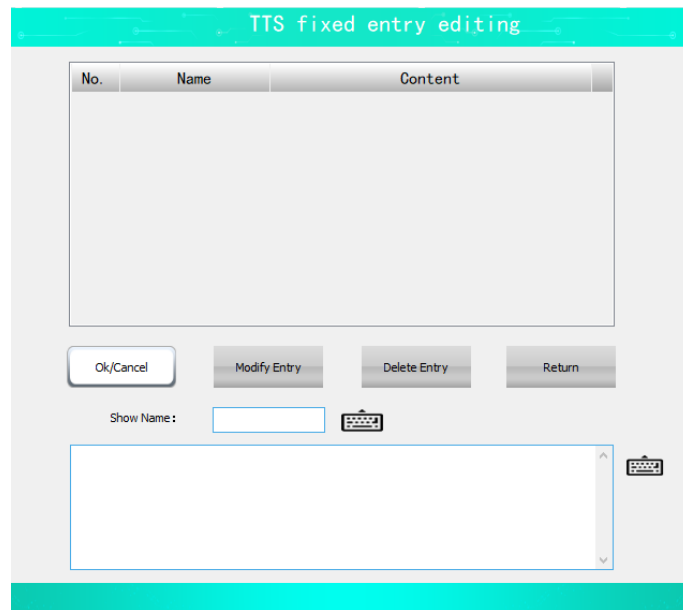

Step 2: In the zone column ③, directly click the zone that needs to play the program, which supports single or multiple selection, and the zone button turns green and with read frame when selected.

Step 3: Click “Play” directly in the play bar ④ to convert the input text into a voice file for playback. It will be stopped to play when you click “STOP” button.

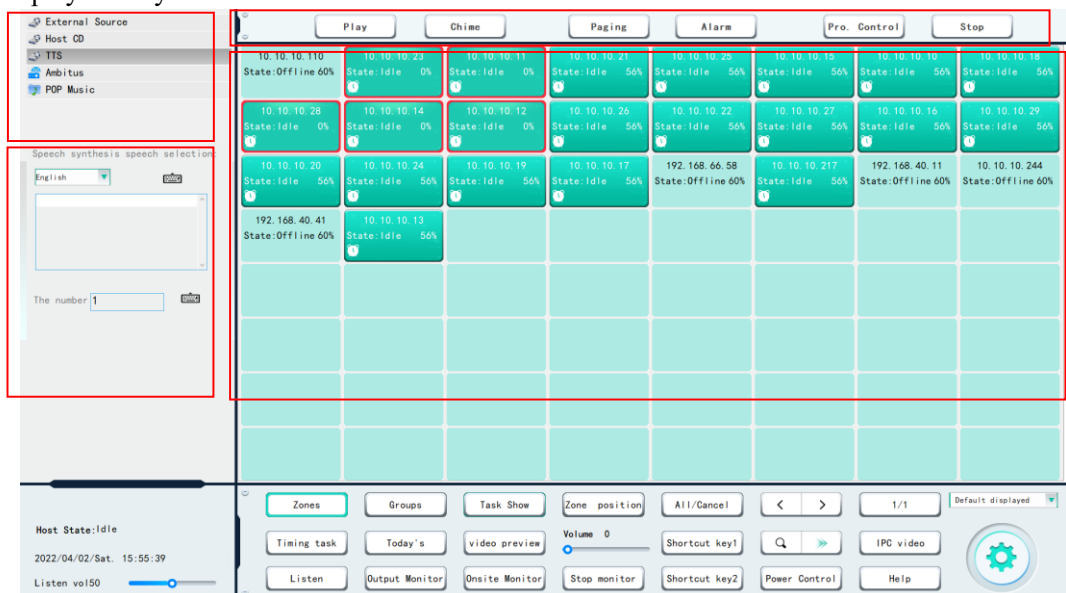

When playing the PC10 peripherals audio source:

Step 1: Select PC10 peripherals audio source in the audio source selection column ①. Please make sure that the audio source access or line

Step 2: Select audio devices in the program list ② (Only **CD Player**, **AM FM Tuner**, and **Pre-amplifier** support playing), which can be classified and displayed according to device types, each device can be remotely controlled.

Step 3: In the zone column ③, directly click the zone that needs to play the program, which supports single or multiple selection, and the zone button turns green and with read frame when selected.

Step 4: Click “Play” directly in the play bar ④, It will be stopped to play when you click “STOP” button.

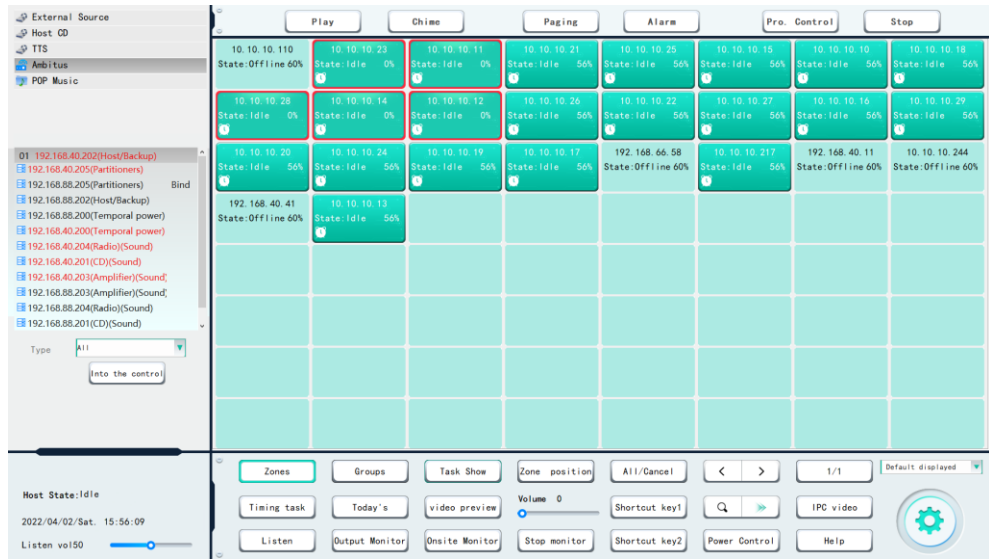

According to the above operation, you can set different zones to play different programs.

4.3.4 Chime

Select the terminal zone where you want to play the chime, click “Chime” to play the chime, and click “Stop” to stop playing the chime, as shown in the figure below.

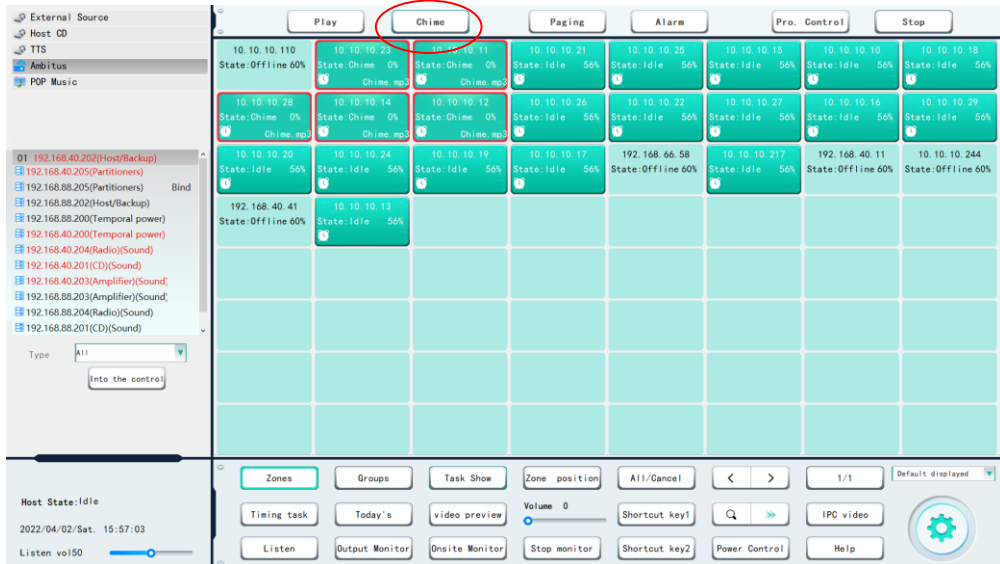

Chime Interface

4.3.5 Host Paging to a Zone

When the host pages a zone, first insert the microphone into the emergency paging interface “EMC MIC”, turn on the microphone switch and click the zone to be paged, and then click the “Page” button in the service broadcast bar to start speaking. After the paging is completed, click the “Stop” button to close the zone or restore the state before paging as shown in the figure below.

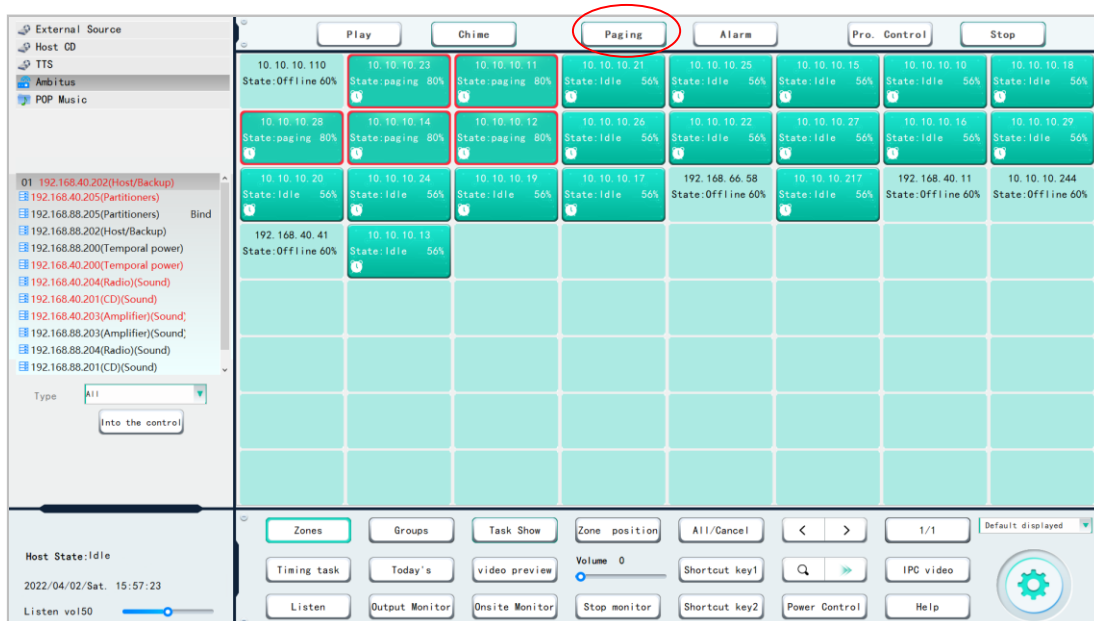

Host Paging Interface

4.3.6 Alarm

Before manual alarm operation, first click the “Settings” button in the lower right corner of the main interface to enter the system settings interface. Set the alarm sound in the “Sound Source Management” for alarming. If not set, the default alarm sound set in the factory will be used when alarming.

System settings interface:

After setting the alarm sound and returning to the main interface, click the “Select All/Cancel” button or directly click the zone to be alarmed, click the “Alarm” button, and the prompt box pops up with “This operation is a red warning, are you sure?”, and select “Yes” to issue the alarm to the zone, and the alarming zones will display with a red flame icon; click the “Stop” button to stop the alarm, as shown in the figure below.

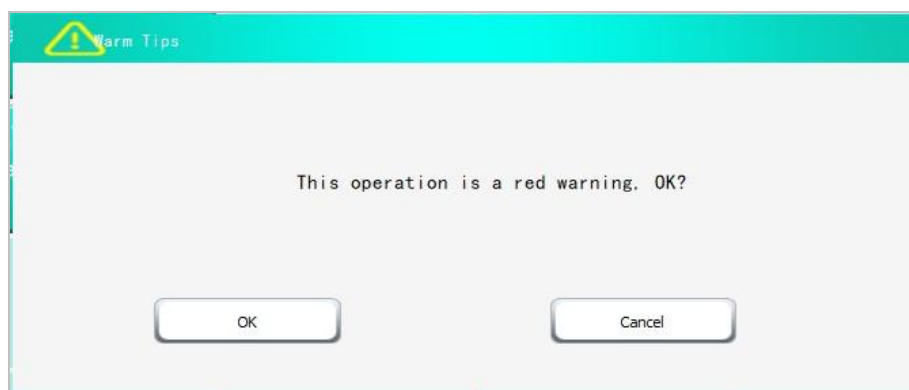

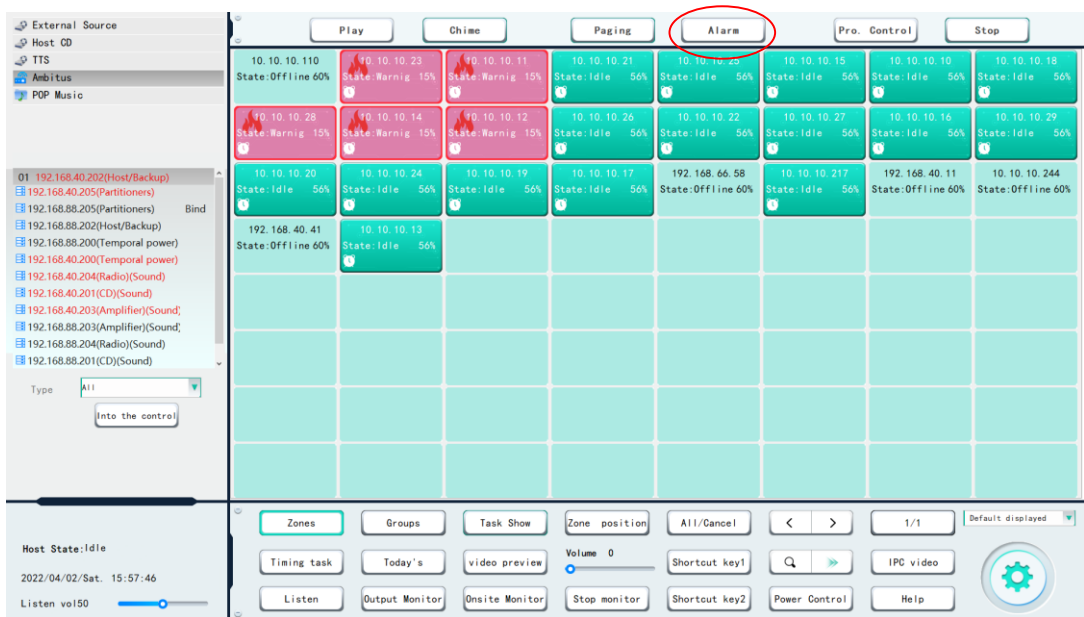

Alarm Interface

4.3.7 Program Control

When the terminal is in the timing state, select the terminal that you want to stop timing, click the “Program Control” button, and the zone/group alarm clock icon  will dim, and the timing work will be stopped, and then click “Program Control”, and the alarm clock icon will resume, but the timing will not work, as shown in the figure below.



Program Control Interface



Program Control Interface

4.3.8 Zone Location

Click the “Zone Location” button to enter the interface as shown in the figure below, where you can view the geographic location of each zone and perform different operations on the zone. Select a single zone, and the icon in the map will display with a red frame to indicate the selected state, and then perform the operations such as

“Play, chime, paging, alarm, program control”. Before using the “Zone Location”, you must first click the “Map Settings” button in the general setting interface of the system settings to set the geographical location of the zone. For specific operation methods, please refer to “Map Settings” operation instructions; as shown in the figure below.

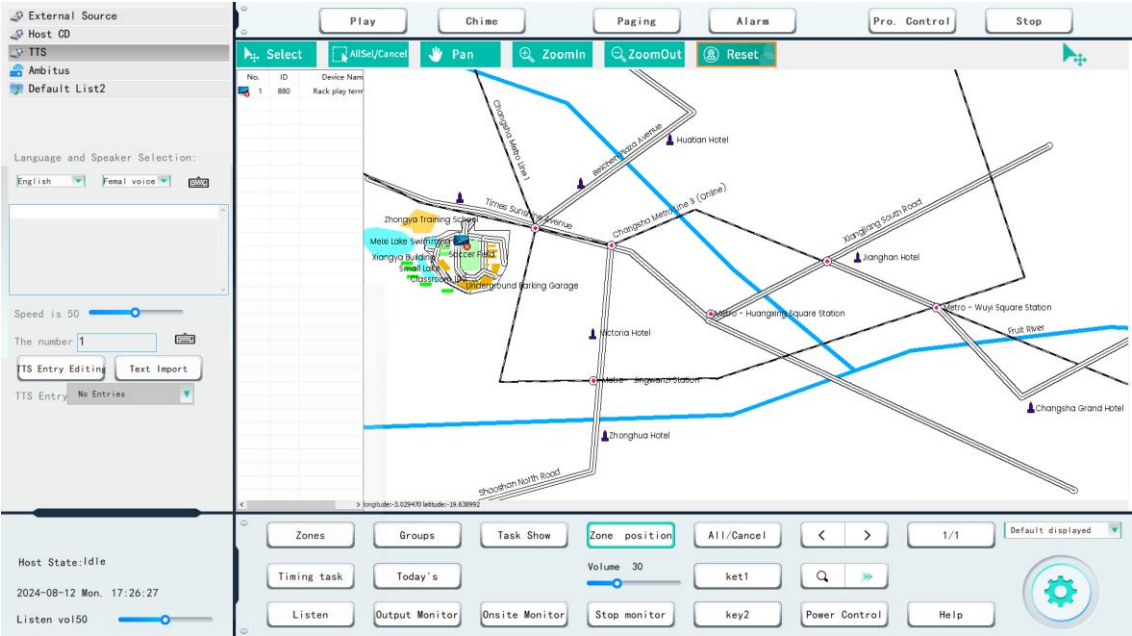

Zone Location Interface

4.3.9 Audio Mixing Broadcast

When the broadcast terminal with the mixing function is broadcasting background music or timing broadcasting, it plays the external audio source connected to the audio capture card, which can realize the mixing broadcast or mixing timing. The proportion of background music can be set in the "System Settings" - "Device Management" - "Mixing Rack Playback Terminal" - "Edit" item below. When playing mixing songs, the volume of MP3 music can be automatically reduced; After the audio mixing is over, the MP3 music volume is automatically restored before the reduction. **Note: The device source priority of the mix output is upgraded to the paging level.**

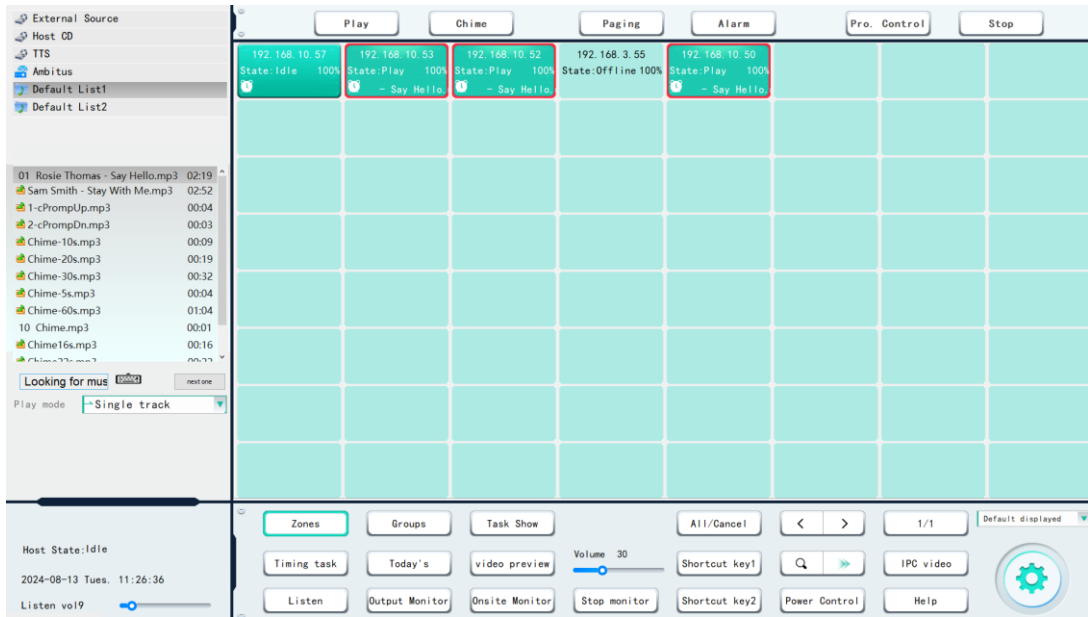

Audio Mixing Broadcast Interface

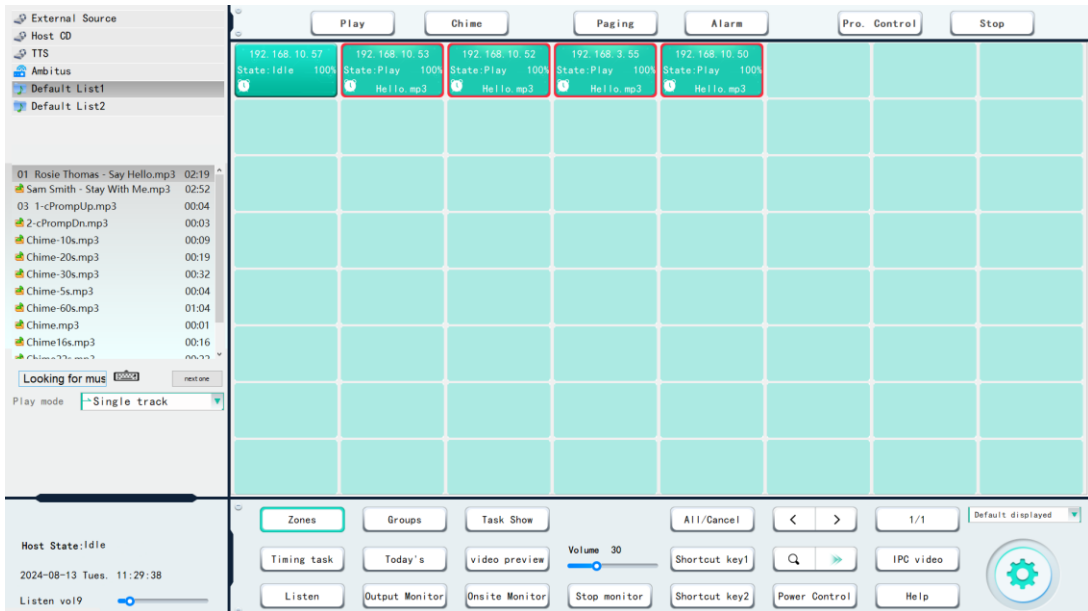

Audio Mixing Timing Interface

4.3.10 Create and Call Timing Plan

There are two timing plans in this system, including regular timing point and campus timing point (choose one of the two plans, please contact our technical staff to operate), please check the operation steps according to the actual situation below.

4.3.10.1 Regular Timing Point Plan

(1) Create Timing Plan

Timing point programming setting is the key to unattended system! Click “Timing Task” on the main interface to enter the “Timing Point Setting” interface, as shown in the figure below. Click the “Plan Operation” button, click the “New” button in the pop-up dialog box, and then enter the plan name and click “OK”. You can also use the

default program. When the timing point is added to the plan, click the “Export” button to export this timing plan to the local, and click the “Import” button to import this timing plan next time you want to use it. Note: You can select the host timing point or other timing points set by the sub-control users for editing in HostTimer.

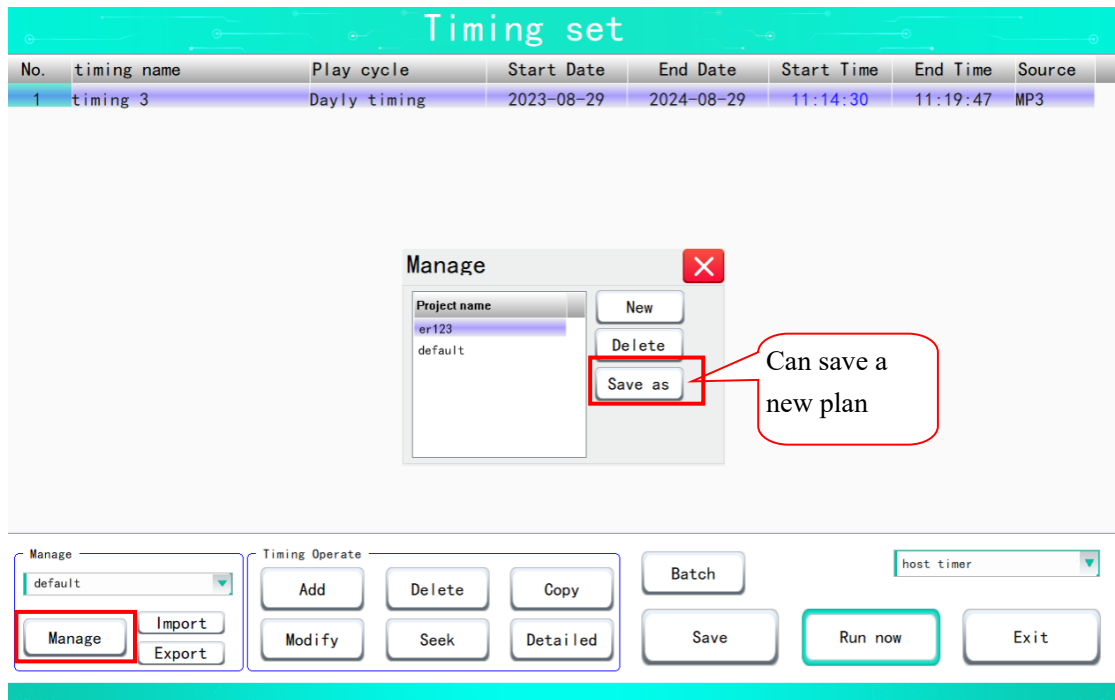

Plan Operation Interface

(2) Call Timing Plan

After setting, select a timing plan (default plan) in “Default Plan” in the “Plan Operation” column, as shown in the figure below, click the “Execute Now” button to call the timing plan.

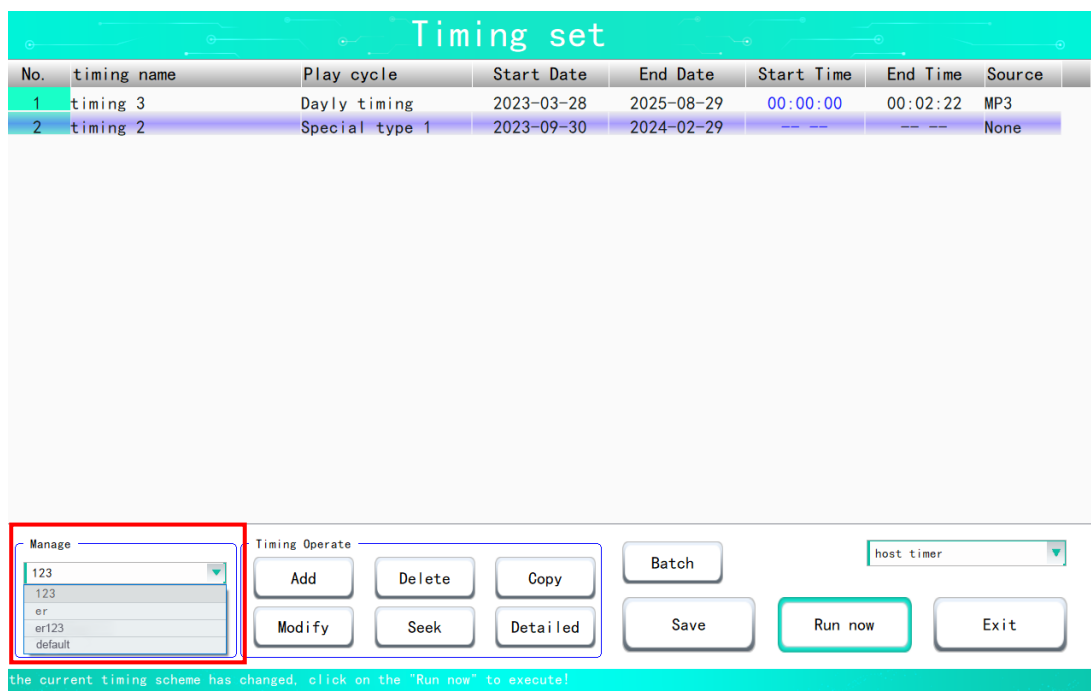

Timing Point Plan Interface

(3) Add Timing Point

Click the “Add” button at the bottom of the interface to pop up the interface as shown in the figure below, and set the execution time of the timing point on this interface. There are three ways to execute timing points: “Daily”, “Weekly” and “Special Timing Point”.

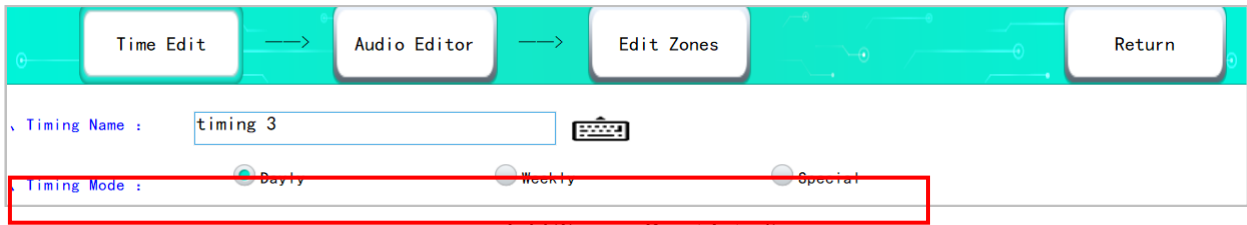

Add Timing Point Interface

① If set “Daily”, it is required to set the start and end time, as well as the specific start time.

Operating steps for “Daily”:

1. Name the timing point.
2. Select the timing point mode as “Daily”, as shown in the figure “Add Daily Timing Point Interface” below.
3. Set the start date, end date and start time.
4. Set whether to control the CH1-CH4 power switch of the host, terminal overridden input (DC-24V) switch and (SC-short circuit) (Rack Power Supply CH1 CH2) output switch regularly.

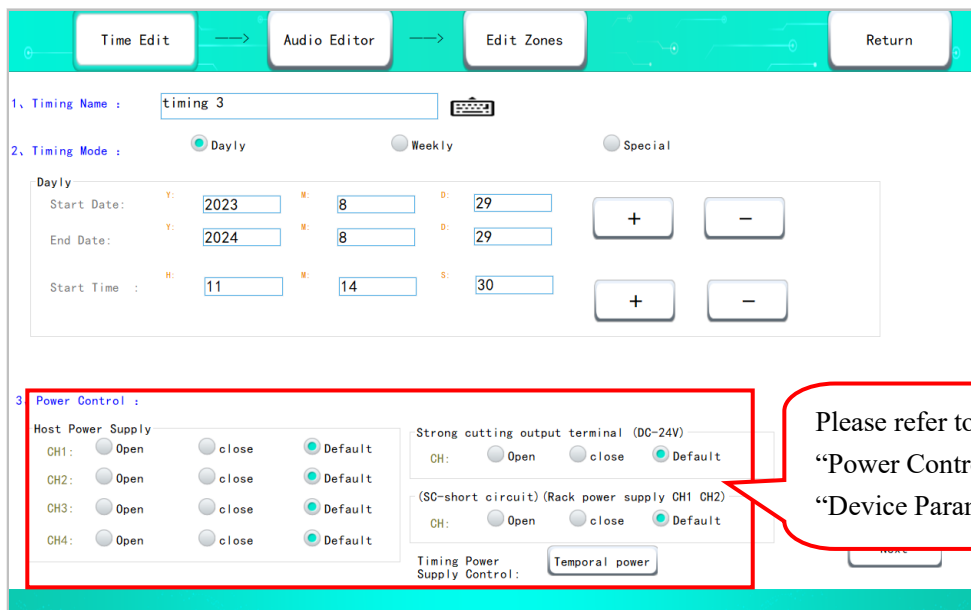

Add Daily Timing Point Interface

5. When connecting Sequence Controller, it can also control the 16-channel power switch of multiple Sequence Controller at the same time.

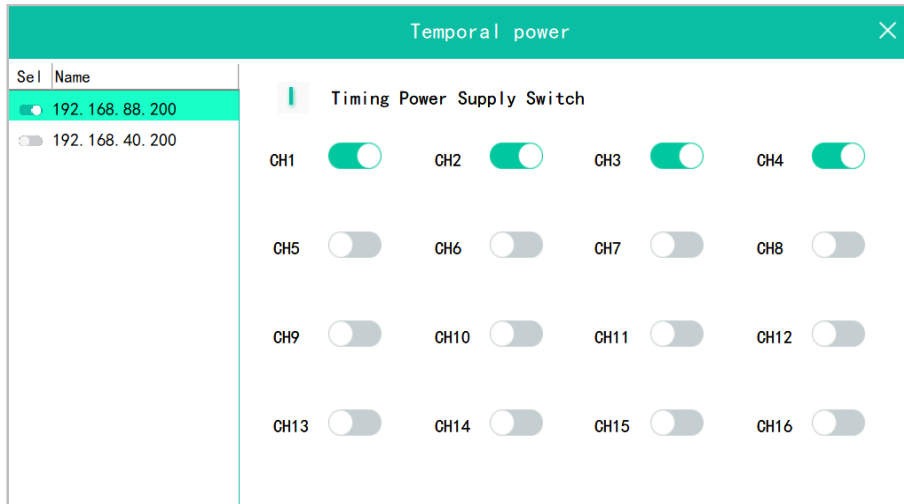

6. Click “NEXT” to enter the editing audio interface.
7. Select the timing type, “General type” or “Insertion type”; Note: “Insertion type” can interrupt “General type”.
8. Select the type of song.
9. Select the play mode.
10. Select program sources that include built-in audio source, external audio source or PC10 audio source device. If PC10 audio source device is selected, you can also check the device under the music list of timing points, and click the "Peripheral Device Control" button to control it; **Note: Only one type of PC10 audio source device can be selected at a timing point!**

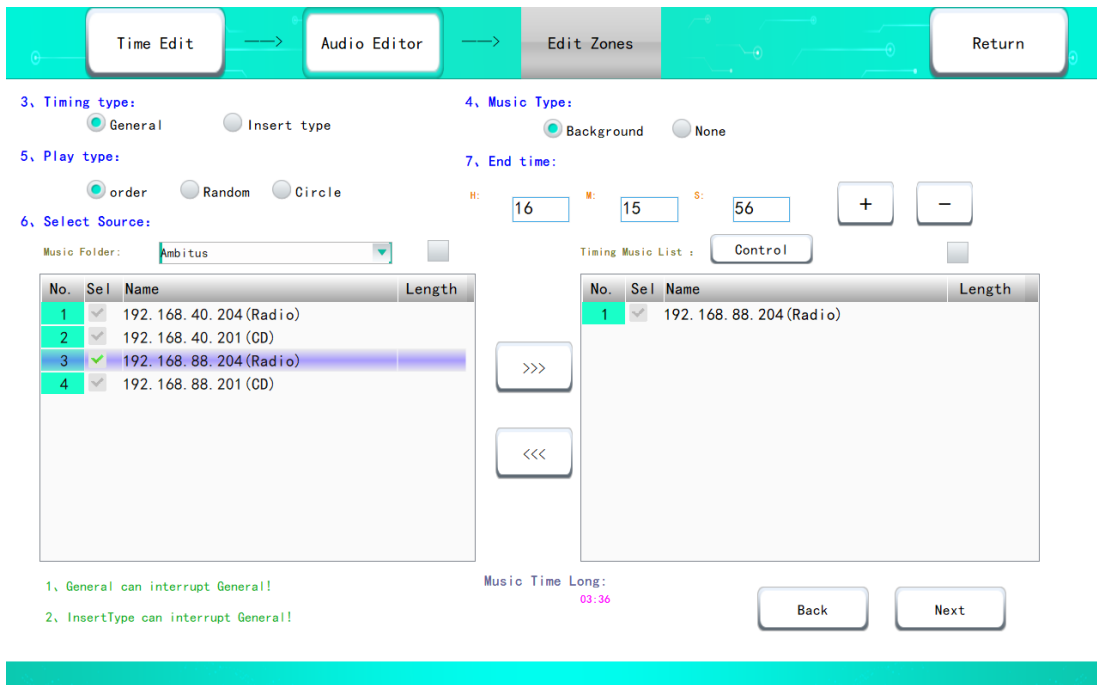

11. Select end time, click the “Next” button to enter zone editing interface.
12. Select the partition or grouping of timing point, and set the “partition switch” bound by the partition of "rack-mounted terminal or networked power amplifier" terminal; Each partitioner has a 10-way partition

switch, when setting the “Partitioner”, you must select a “rack-mounted terminal or networked power amplifier” terminal partition under the timing point partition list, and “rack-mounted terminal or networked power amplifier” need to be selected in advance in the “Device Management” interface of “System Settings” in order to bind the partitioner, finally set the volume and click “Complete”

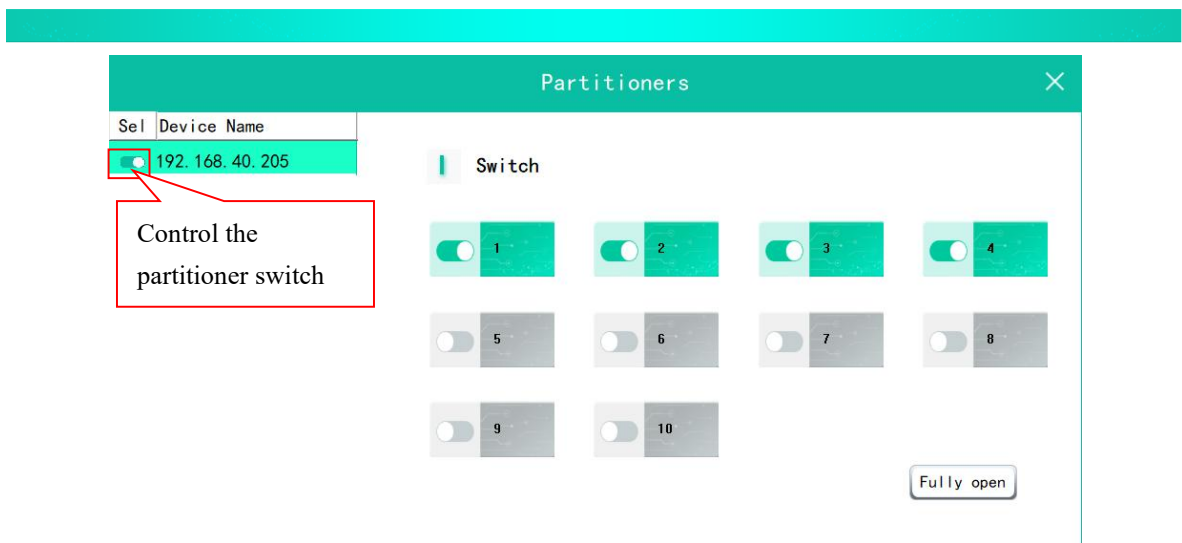
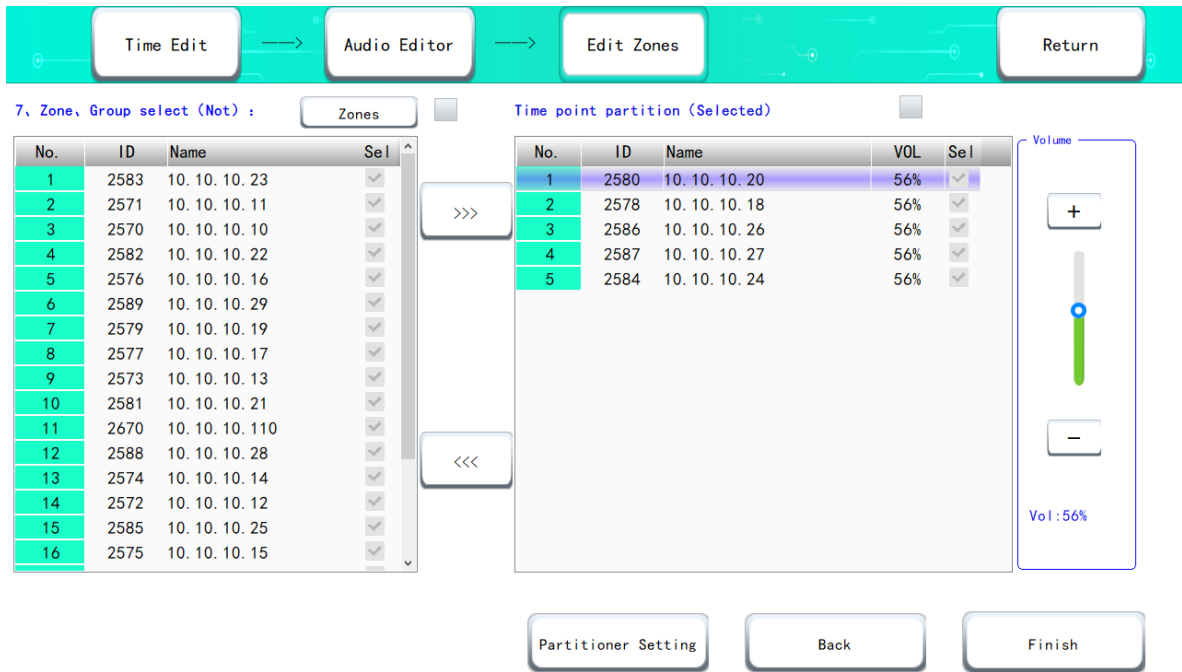

13. After automatically returning to the “Timing Set” interface, please note that you have to click the “Save” button, and then the next time you can open the record, as shown in the figure Add Daily Timing Point Interface below.

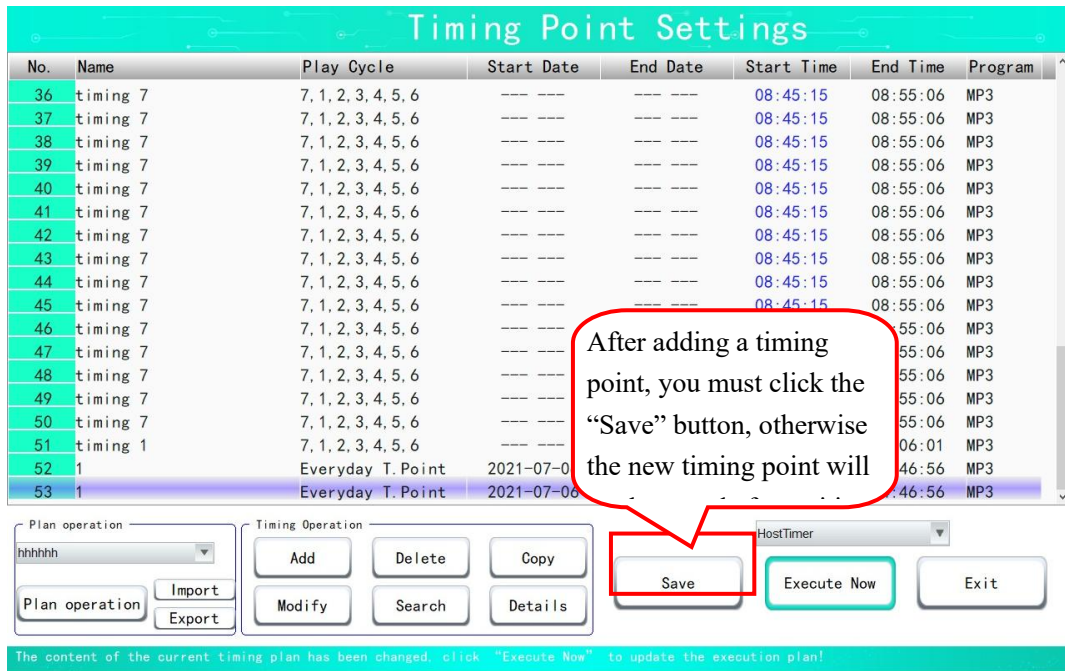

Timing Point Settings Interface

② “Weekly” refers to weekly cycle of the selected days of a week, and it is required to set the start time, and set the cycle time in the “Weekly” column below.

Operating steps for “Weekly”:

In the weekly cycle setting, select the day that needs to execute the timing point and set the start time:

1. Name the timing point.
2. Select the timing point mode as “Weekly”, as shown in the figure below.
3. Tick before the day to be executed.
4. Set the start time.
5. Set whether to control the CH1-CH4 power switch on the rear panel of the host, terminal overridden input (DC-24V) switch and (SC-short circuit) (Rack Power Supply CH1 CH2)output switch regularly.
6. When connecting Sequence Controller, it can also control the 16-channel power switch of multiple Sequence Controller at the same time.
7. Click the “Next” button to enter the audio editing interface.
8. Select the timing type, “General type” or “Insertion type”; Note: “Insertion type” can interrupt “General type”.
9. Select the type of song.
10. Select the play mode.
11. Select program source that include built-in audio source, external audio source or PC10 audio source device. If PC10 audio source device is selected, you can also check the device under the music list of timing points, and click the "Peripheral Device Control" button to control it; Note: **Only one type of PC10 audio source device can be selected at a timing point!**
12. Set the end time, click the “Next” button to enter zone editing interface.
13. Select the partition or grouping of timing point, and set the “partition switch” bound by the partition of "rack-mounted terminal or networked power amplifier" terminal; Each partitioner has a 10-way partition switch, when

setting the “Partitioner”, you must select a “rack-mounted terminal or networked power amplifier” terminal partition under the timing point partition list, and “rack-mounted terminal or networked power amplifier” need to be selected in advance in the “Device Management” interface of “System Settings” in order to bind the partitioner, finally set the volume and click “Complete”.

14. After automatically returning to the “Timing Set” interface, please note that you have to click the “Save” button, and then the next time you can open the record, as shown in the figure Add Daily Timing Point Interface below.

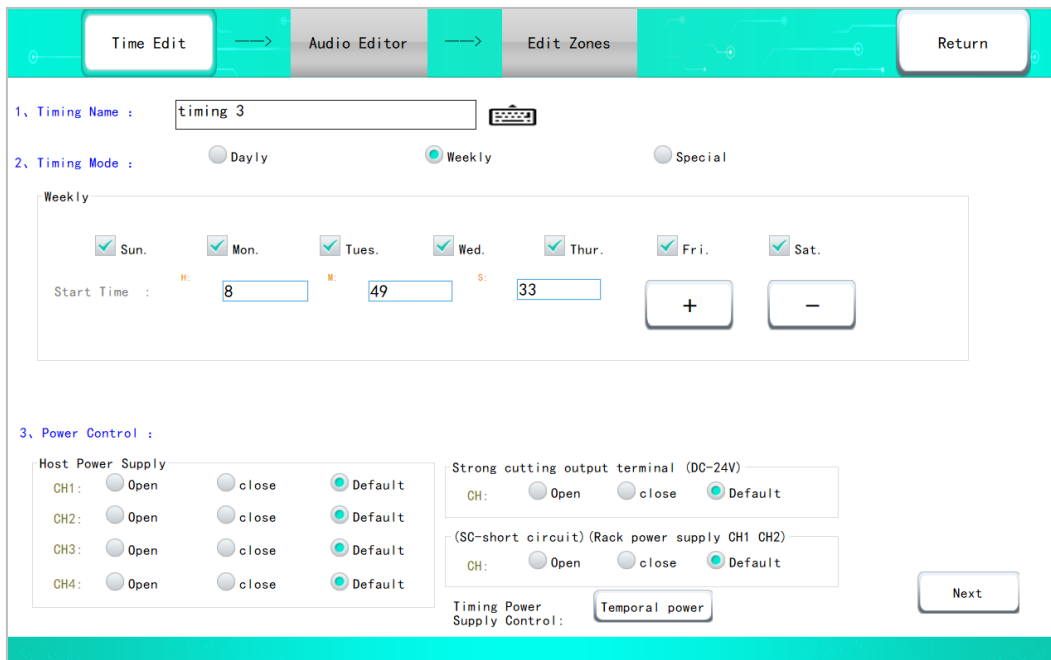

Add Weekly Timing Point Interface

③ “Special Timing Point” means that the timing plans of “Weekly” and “Daily”, “Weekly” or “Daily” will not be executed during this time period. For example, select the special timing point 2. It means that during this timing point, all set “Weekly” timing points will not be executed. (Special timing point 1: the timing points added by “Weekly” and “Daily” within the date range will not be executed; special timing point 2: the timing points added by “Weekly” within the date range will not be executed; special timing point 3: the timing points added by “Daily” within the date range will not be executed.)

Operating steps for “Special”:

1. Name the timing point.
2. Select the timing point mode as “Special Timing Point”, as shown in the figure below.
3. Set the task start date and end date.
4. Select the special timing point 1, special timing point 2 or special timing point 3.
5. Set whether to control the host CH1-CH4 power switch, terminal overridden input (DC-24V) switch and (SC-short circuit)(Rack Power Supply CH1 CH2) output switch regularly.
6. When connecting Sequence Controller, it can also control the 16-channel power switch of multiple Sequence Controller at the same time.
7. Click “Finish” button, after automatically returning to the “Timing Set” interface, please note that you have to

click the “Save” button, and then the next time you can open the record.

Add Special Timing Point Interface

Timing set							
No.	timing name	Play cycle	Start Date	End Date	Start Time	End Time	Source
1	timing 3	Dayly timing	2023-03-28	2025-08-29	00:00:00	00:02:22	MP3
2	timing 2	Special type 1	2023-09-30	2024-02-29	-- --	-- --	None
3	timing 3	Special type 1	2023-08-31	2023-08-31	-- --	-- --	None
4	timing 4	Special type 1	2023-08-31	2023-08-31	-- --	-- --	None

Manage

Timing Operate

host timer ▼

the current timing scheme has changed. click on the "Run now" to execute!

Timing point operation column

Add function: Can add a new timing point.

Modify function: Select the timing point to be modified, and click “Modify” to modify the current timing point.

Delete function: Select the timing point to be deleted, and click “Delete” to delete the current timing point.

Copy function: Select the timing point to be copied, and click “Copy” to copy the current timing point.

Search function: Click “Search” to pop up the timing point search dialog box, and enter the name of the timing point or set the time period to search the timing point.

- When searching by the name of the timing point, click the small keyboard icon to enter the name, and tick Name under “Filtering Items”, and then click “OK”.

- When searching by the time period, first set the cursor in the input box of start time and end time (hour, minute, second), then click the symbol “+” or “-” behind to set the time, and finally tick Time Period under “Filtering Items”, and then click “OK”.

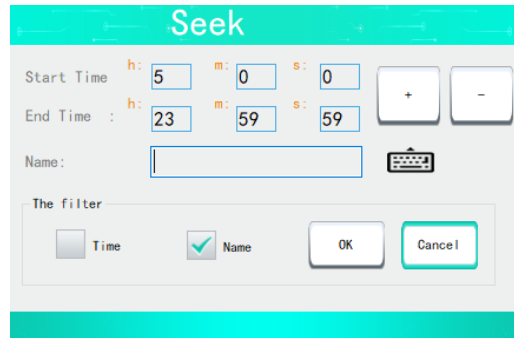

Detailed information: Select a timing point, and click “Detail” to view details of the timing point.

Batch Setting: You can modify all the timing points of the current timing scheme in batches, click "Batch Processing" to enter the interface as shown below, you can modify the music (timing point sound source) or partition of the timing point, the audio source or partition checked in the left list is added to the ticked time point on the right side by the ">>>" key or deleted from the right ticked time point by the "<<<" key; There will be a text prompt for successful deletion. When modifying the timing point partition, you can modify the volume level of one or more partitions in advance; After adding successfully, you can view it in "Detailed", click "Search" to see to which timing point the selected partition is assigned, and then click "Save" to finish.

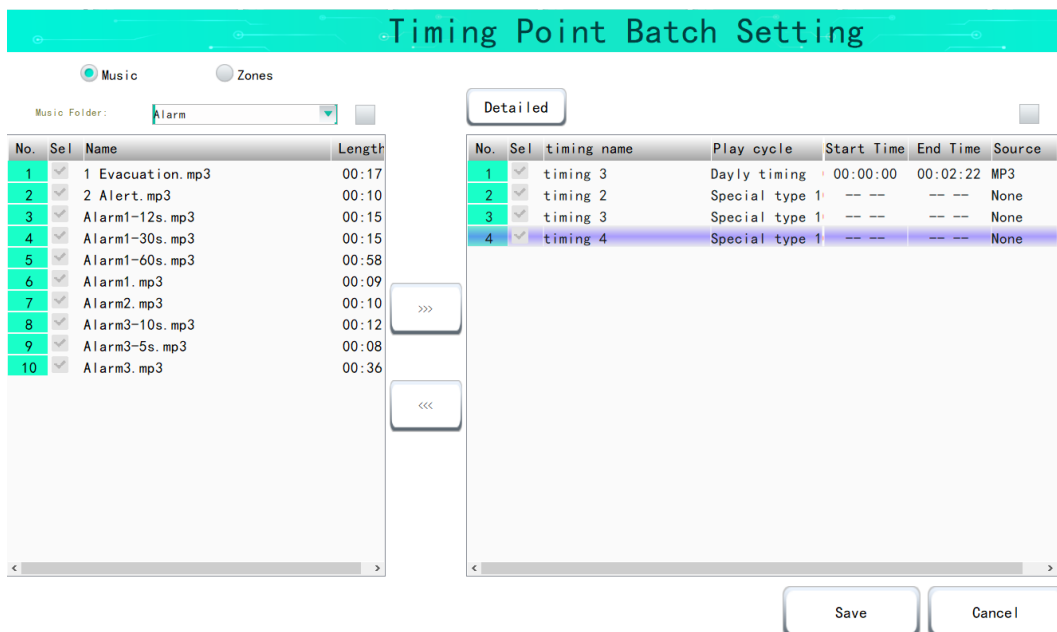

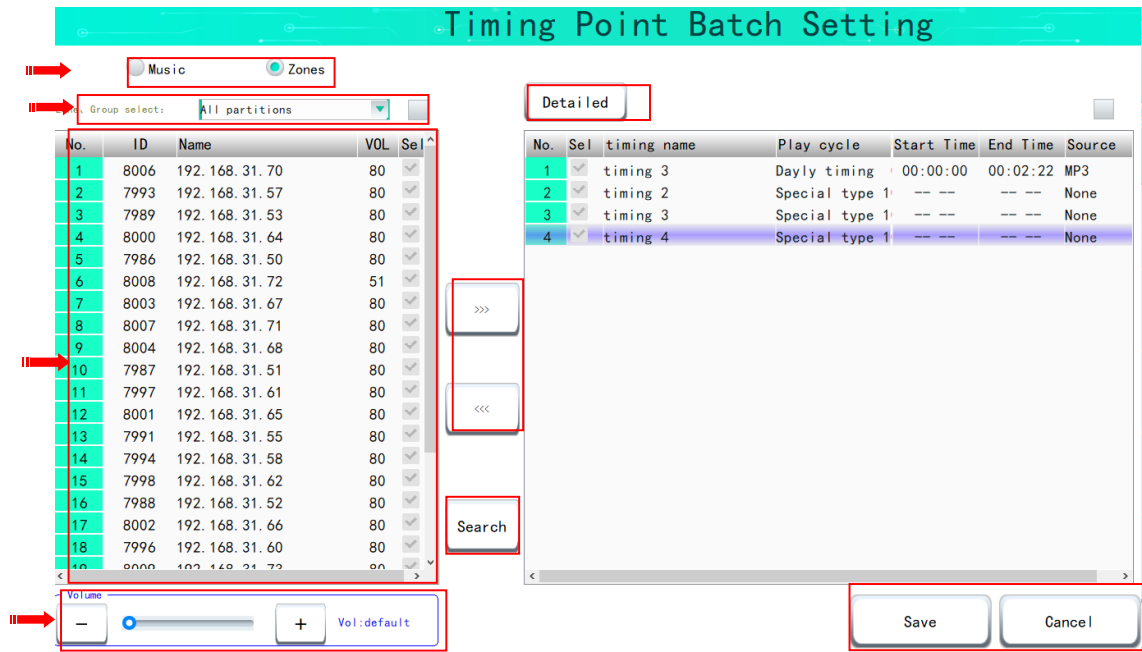

Note: The above content is related to timing point plan settings. It is to save a set timing point timetable as a plan in the system for future use. Multiple timing plans can be saved in the system. In schools, if the timetable of odd-numbered weeks is different from that of even-numbered weeks, it is supposed to set two timing plans for future call in turn. In some regions, the timetables in summer and other seasons are different, so it is supposed to set various timetables and save in the system for future use.

4.3.10.2 Campus Timing Point Plan

This is a timing point editing function for special application scenarios in schools. It can meet the needs of different timing points such as school holidays, class adjustments, and various exams, allowing users to quickly and intelligently edit timing point content.

Click the "Timing Task" button on the main interface to enter the "Timing Point Setting" interface as shown in the figure below;

- "Add" button: You can add a timing point task, you need to perform plan operation and template operation first; the added timing point task will be displayed in the list below;
- "Manage" button: Timing plans can be added by partitioning. Before adding timing point tasks, you need to add a timing plan first;
- "Template" button: You can set various campus ringtones, music, etc., and add multiple sub-timing points, and add multiple start time choices for editing timing points. Adding tasks to a timing point can generate multiple task points; Please perform template operations before adding a timing point task.



Timing Point Settings Interface

(1) “Manage” Operation

Select the "Manage" button to pop up the interface shown below. You can add multiple timing plans and divide the timing plans through partitions. Multiple timing plans can be saved in the system and executed simultaneously.

Click the "Add" button to enter the plan name (such as senior high school, whole district, etc.). After confirmation, the plan name will be displayed under the list on the left side of the interface. Then move the corresponding partition left to the middle list, and then click "Save" to successfully add the plan. Timing plans added in the sub-control software and WEB side will also be displayed here simultaneously; up to 100 plans can be added (including sub-control software and WEB side).

The selected timing scheme can be moved up, down, topped, deleted, and modified; You can also set to enable or disable timing schemes; When disabled, the timing scheme will not be executed.

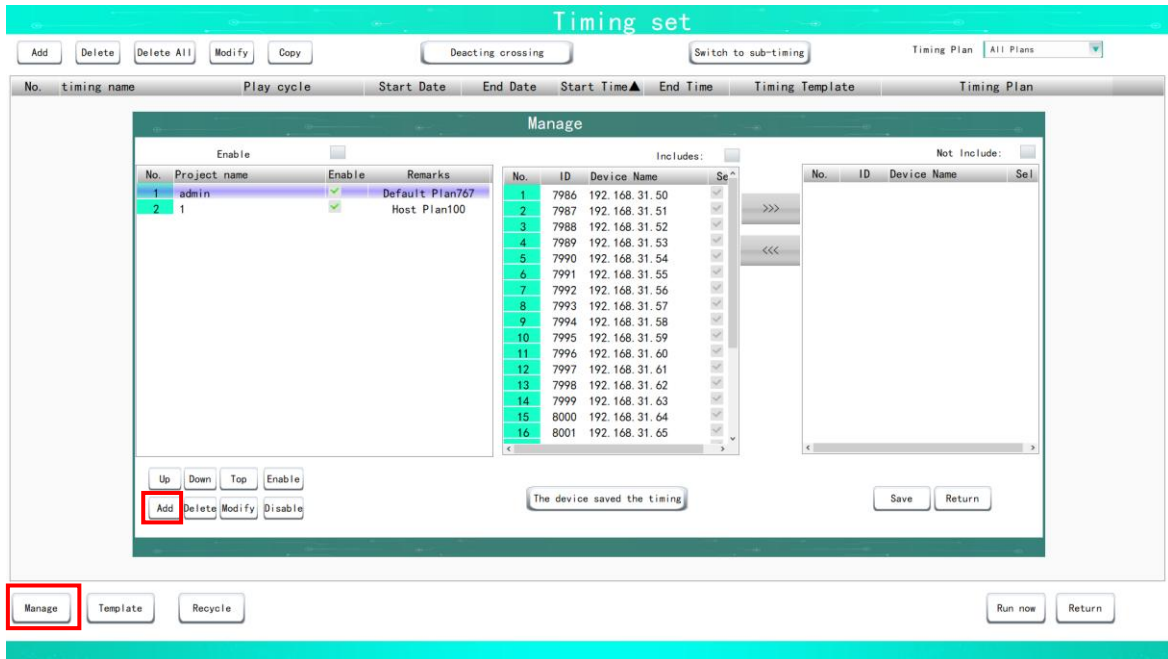

“Manage” Operation Interface

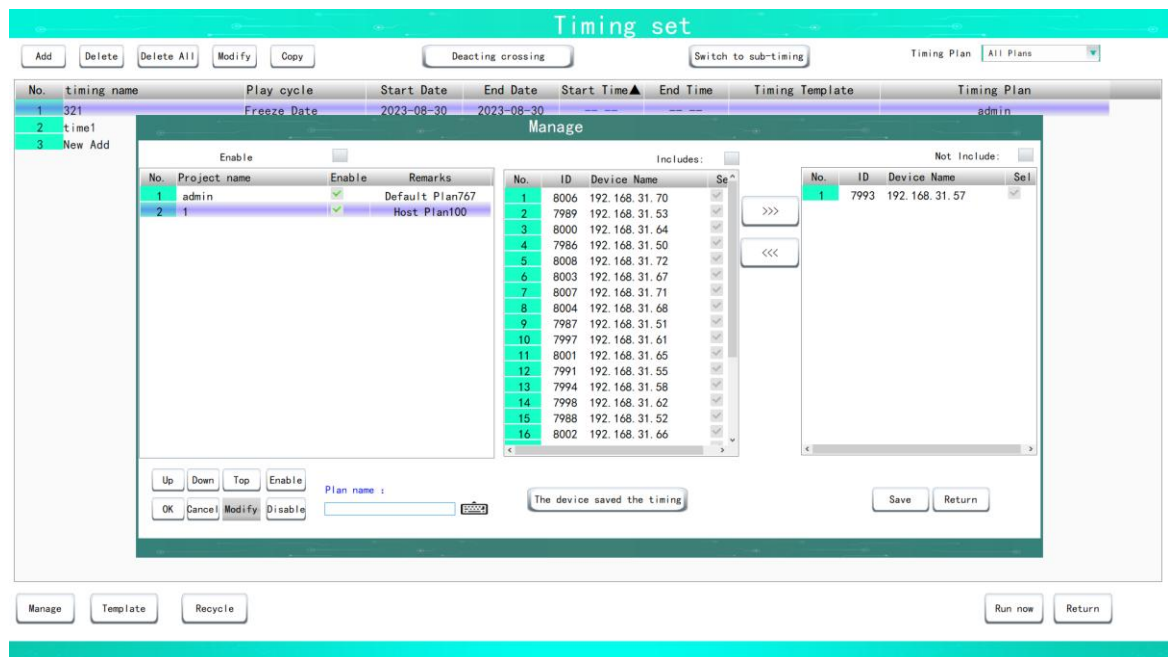

(2) “Template” Operation

Select the "Template" operation button to pop up the following interface, you can add multiple timing templates, a template allows users to add multiple sub-tasks, but please pay attention to the time crossover problem.

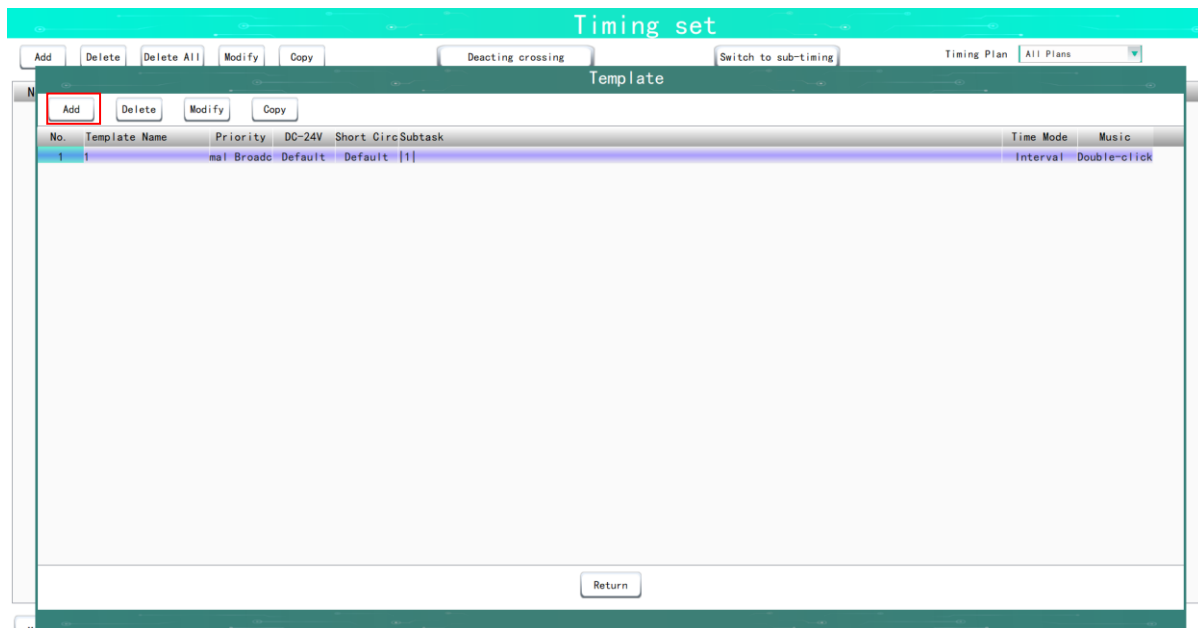

“Template” Operation Interface

The steps to add a template are as follows:

1. Click the "Add" button to enter the name of the plan (such as the school bell, the school bell, etc.);
2. Set priority to a “General type” or “Insertion type”; Note: “Insertion type” can interrupt “General type”.
3. Set timing point (DC-24V) control output is on, off or not;
4. Set timing point (SC-short circuit) control output is on, off or not;

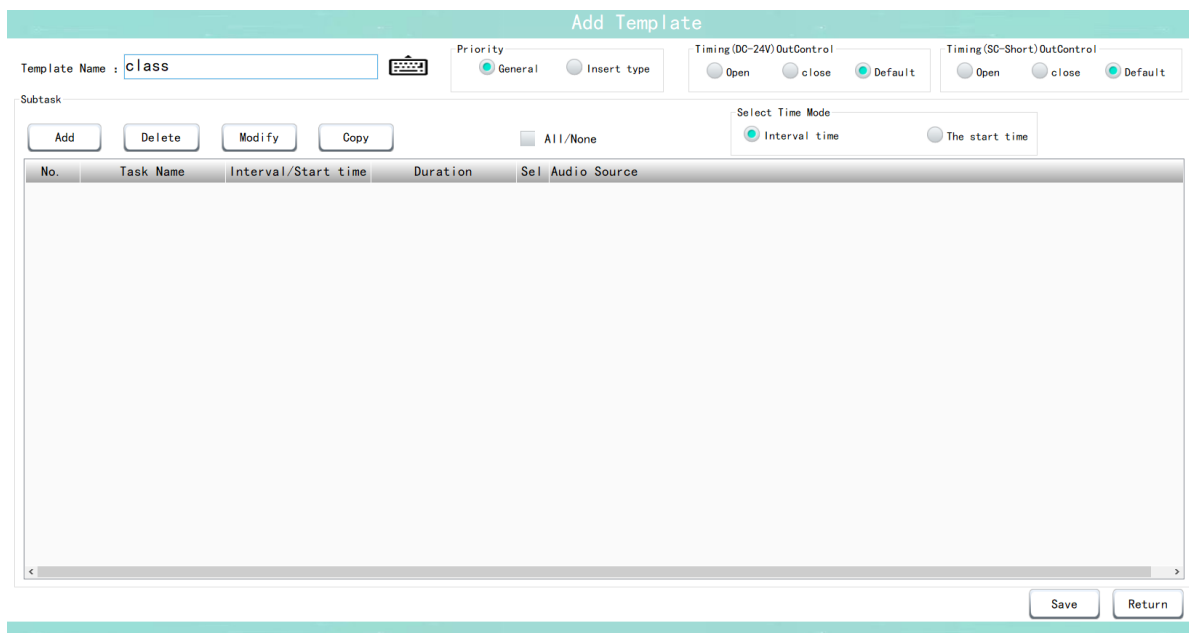

Add Template Interface

5. Click the "Add" button to enter the interface for adding subtask as shown below; enter the task name;

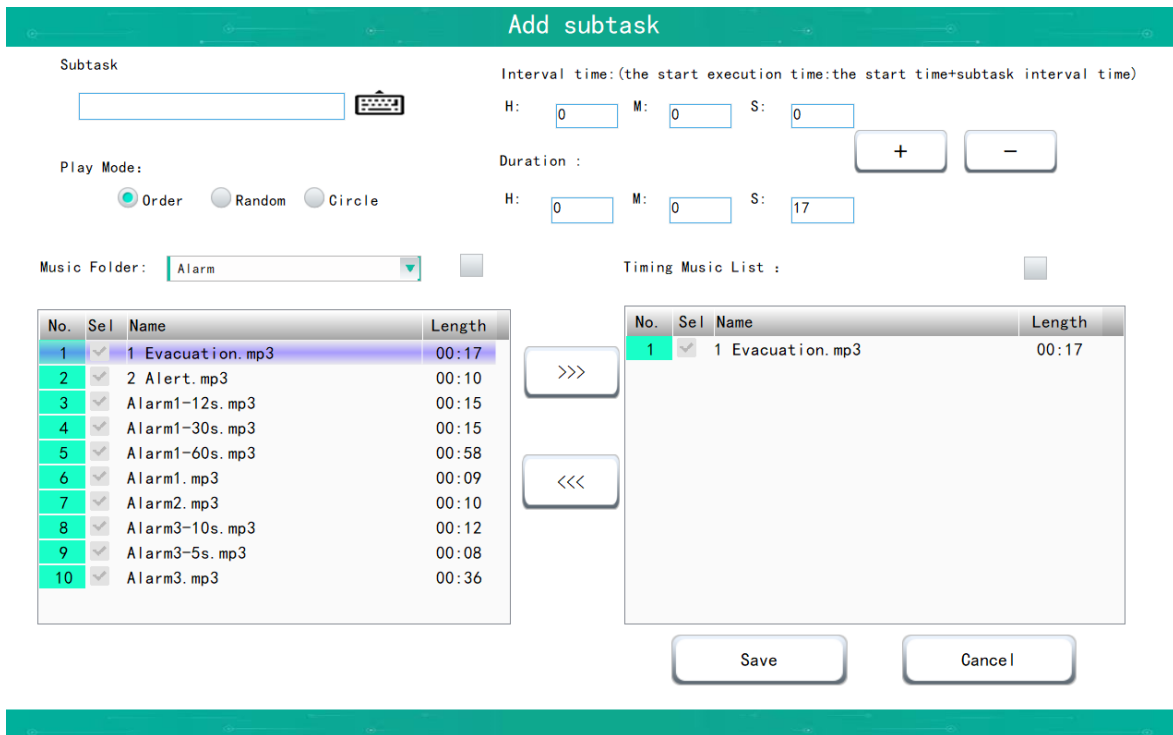

Add Subtask Interface

6. Select the playback mode: sequential playback, random playback and loop playback;
7. Set the interval time and duration: hour, minute, second, set by "+"/"-", the time setting is at least 10 seconds; For example, the interval between the start and end of class is 45 minutes or the interval between the preparatory bell and the class bell is 3 minutes, etc.; The end-of-class bell lasts 20 seconds; it can be set according to actual needs;
8. Choose a campus ringtone or music program, etc.;
9. Then click the OK button and the added subtasks appear in the following diagram list. Then click the Save button.

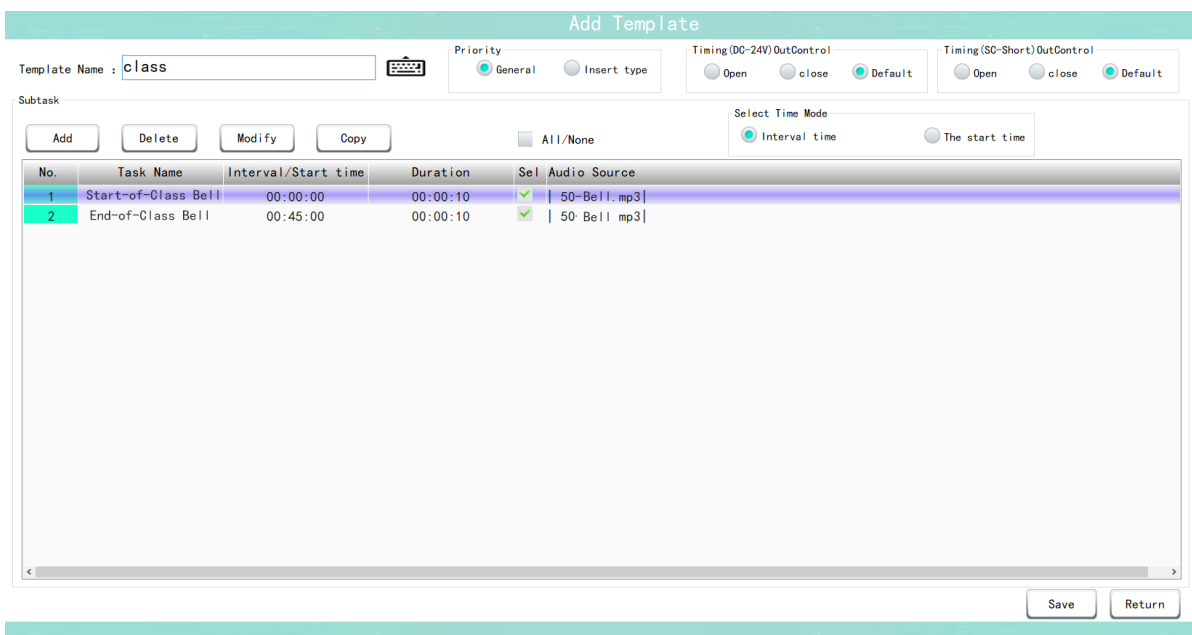

(3) Add Timing Point

Touch the "Add" button above the timing point setting interface to pop up the interface as shown in the figure

below, and set the execution time of the timing point on this interface. There are three execution modes of timing points: "week cycle", "power control" and "special timing point".

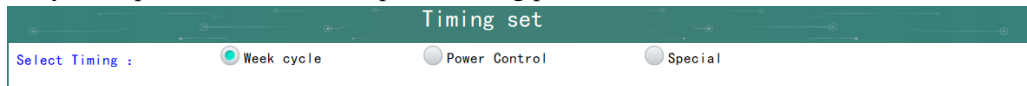

① "Week Cycle" means that a specific partition will periodically execute campus scheduled programs on specific days of each week from the start time;

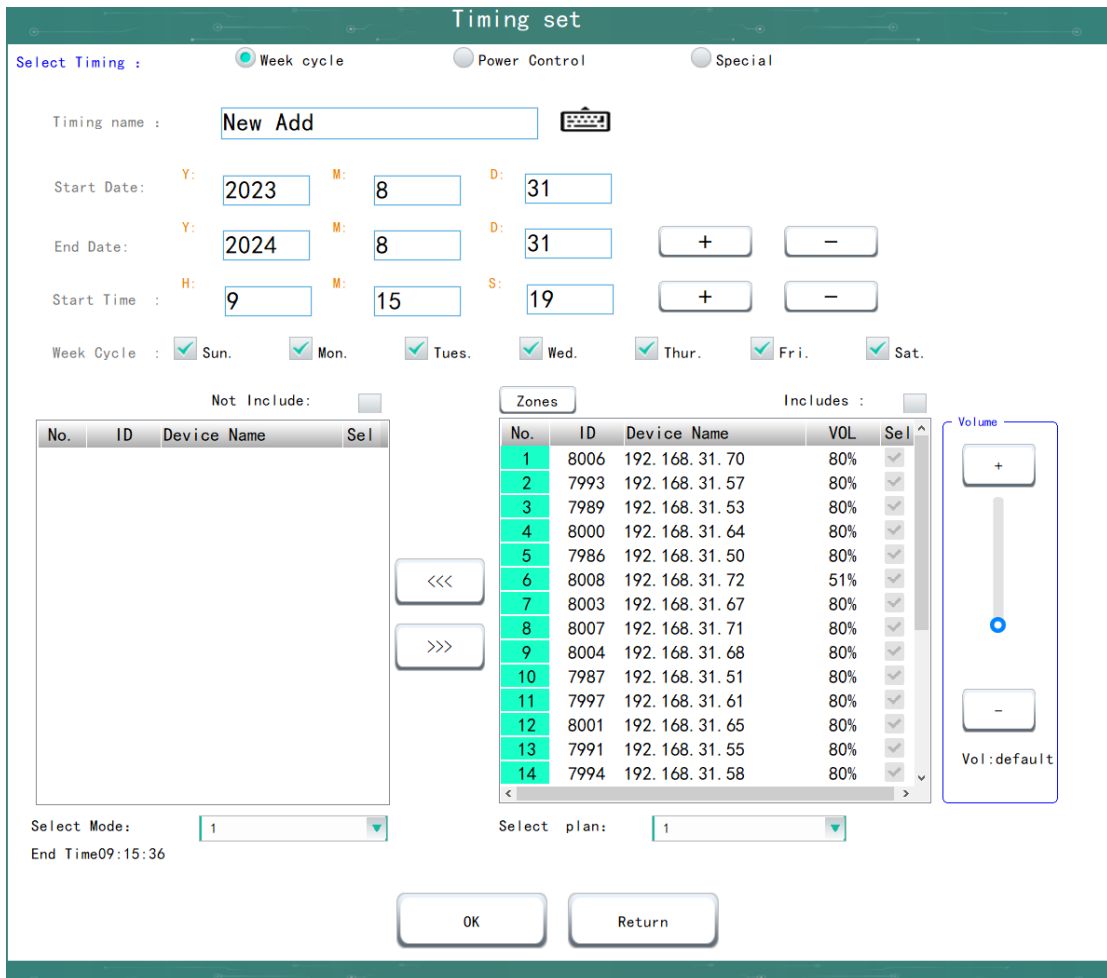

The setting steps of "Week Cycle" mode are as follows:

1. Select the timing point method as "week cycle", as shown in the figure above;
2. Name the timing point;
3. Set the task start date, end date and start time;
4. Tap and tick before the week that needs to be executed;
5. Select timing templates such as class bell, end bell, etc.;
6. Select a timing plan such as the whole district, primary school, etc.; after selection, the partitions in the plan will be displayed in the list above. You can increase or decrease partitions and set the timing volume; and you can set the "partition switch" bound by the partition of "rack-mounted terminal or networked power amplifier" terminal; Each partitioner has a 10-way partition switch, when setting the "Partitioner", you must select a "rack-mounted terminal or networked power amplifier" terminal partition under the timing point partition list, and "rack-mounted terminal or networked power amplifier" need to bind the partitioner in advance in the "Device Management" interface of "System Settings", then control each partition switch of the partitioner bound to the "rack terminal or network power amplifier", as shown in the figure below.

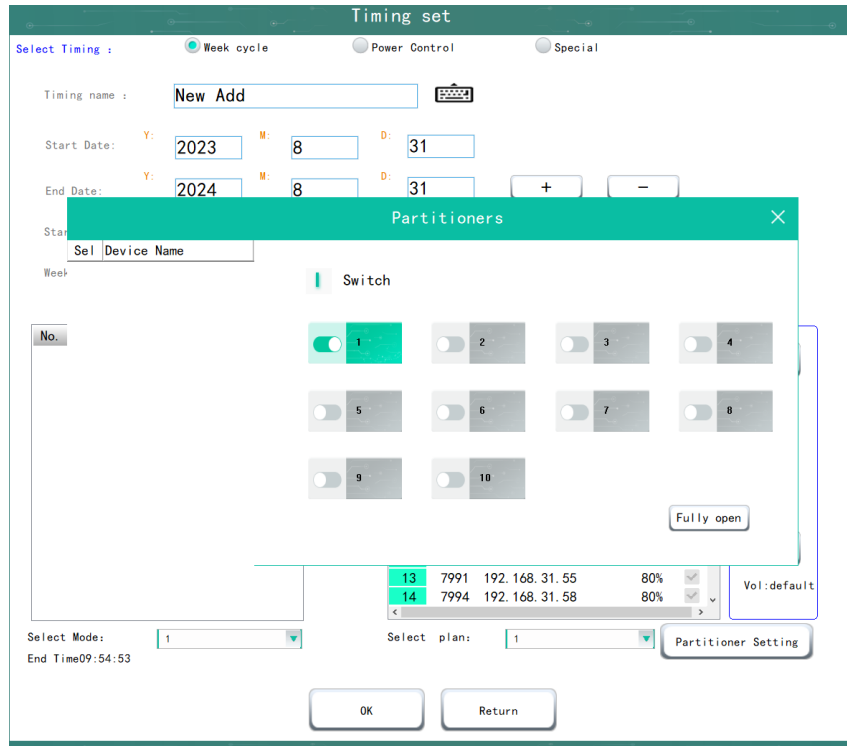

7. Click the "OK" button to add successfully, return to the previous interface, the added timing point will be displayed in the list of the previous interface.

② "Power Control" means that a specific partition will control the host power supply and power sequence controller operating status at a specific time every week from the start time;

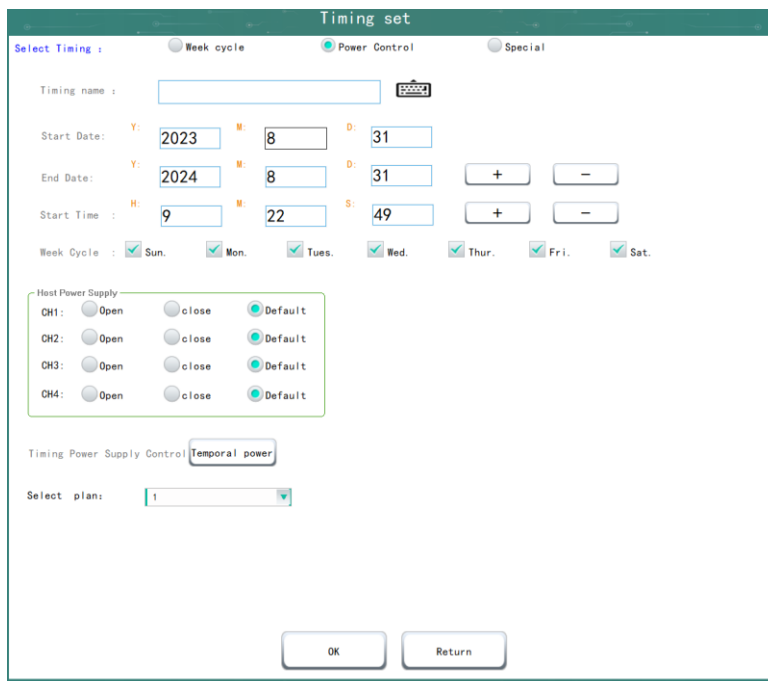

The setting steps of "Week Cycle" mode are as follows:

1. Select the timing point method as "week cycle", as shown in the figure above;
2. Name the timing point;
3. Set the task start date, end date and start time;

4. Tap and tick before the week that needs to be executed;
5. Select the four-way power switch status connected to the host;
6. After connecting to the power sequence controller, you can also control the 16-channel sequential power switches of multiple power sequence controllers at the same time, as shown below;

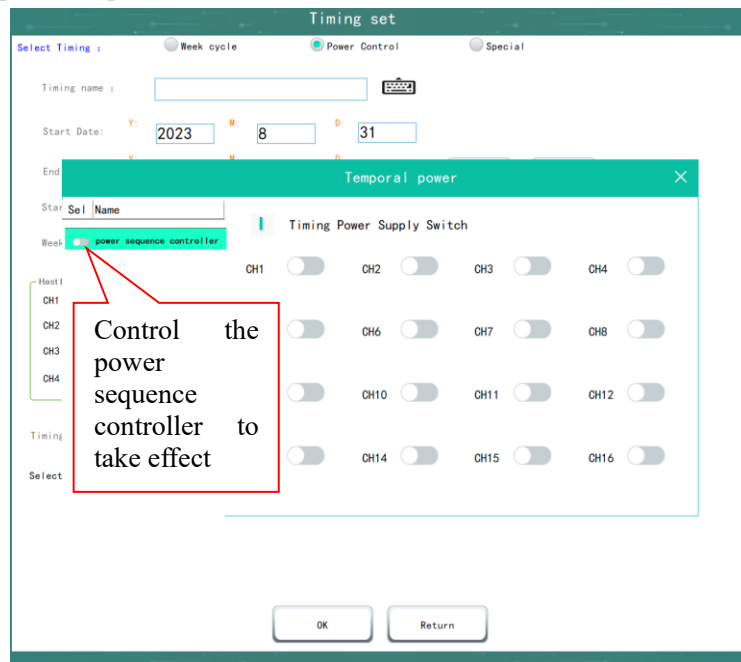

7. Select a timing plan such as the whole district, primary school, etc.;
 8. Click the "OK" button to add successfully, return to the previous interface, the added timing point will be displayed in the list of the previous interface.
- ③ "Special Timing Point" item can set freeze date and holiday course adjustment; freeze date means that all timing points of the current plan will not be executed during the period from "task start date" to "task end date"; Holiday course adjustment means that it is hoped to execute the scheduled content of the day of a week on a certain day.
- The freeze date setting steps are as follows:
 1. Select the timing point mode as "Special timing point", as shown in the figure below;
 2. Name the timing point;
 3. Set the task start date and end date;
 4. The timing type is set to freeze date;
 5. Select a timing plan such as the whole district, primary school, etc.;
 6. Click the "OK" button to add successfully, return to the previous interface, the added timing point will be displayed in the list of the previous interface.

Timing set

Select Timing : Week cycle Power Control Special

Timing name :

Start Date: Y: 2023 M: 8 D: 31

End Date: Y: 2023 M: 8 D: 31 + -

Timing type : Freeze Date Holiday

All timing points of the current plan will not be executed during the period from "Start Date" to "End Date"

Select plan: 1

OK Return

- The holiday course adjustment setting steps are as follows:
 1. Select the timing point mode as "Special timing point", as shown in the figure below;
 2. Name the timing point;
 3. Set the task start date and end date, that is, the time required to adjust course (by day);
 4. The timing type is set to holiday course adjustment;
 5. Select the course to be called on a certain day;
 6. Select a timing plan such as the whole district, primary school, etc.;
 7. Click the "OK" button to add successfully, return to the previous interface, the added timing point will be displayed in the list of the previous interface.

Timing set

Select Timing : Week cycle Power Control Special

Timing name :

Start Date: Y: 2023 M: 9 D: 4

End Date: Y: 2023 M: 9 D: 4 + -

Timing type : Freeze Date Holiday

Select one day Sun. Mon. Tues. Wed. Thur. Fri. Sat.

Adjust the course on holidays, and hope to implement the scheduled content of the day of the week on the day!

Select plan: 1

OK Return

All the added timing points are displayed in the timing point setting interface in the figure below; you can perform

the following operations on the timing points:

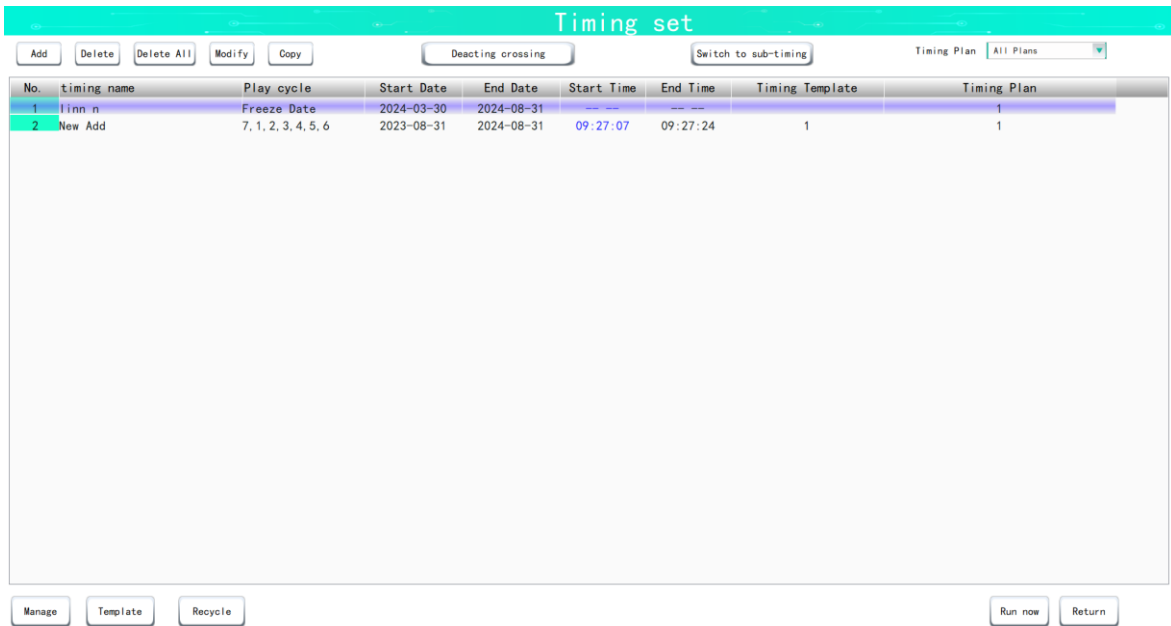

- “Delete”/ “Delete All” button: can delete/delete all selected scheduled tasks;
- “Modify” button: can modify the scheduled task, including the plan and template;
- “Copy” button: can copy any timing point task;
- “Detecting crossing” button: it can detect whether there is an intersection between partitions and time in the timing point task
- “Switch to sub-timing” button: You can first select a timing plan in the "Timing Plan" bar in the upper right corner of the interface, and then switch to view the main timing points in the current timing plan and sub-timing points in the template with one click.



- “Run Now” button: the timing point will be executed immediately, and the set time will be replaced by the time after execution.

- “Return” button: return to the previous interface.
- “Recycle” button: backup the content before each scheduled modification, which can restore the timing point that the user accidentally deleted.

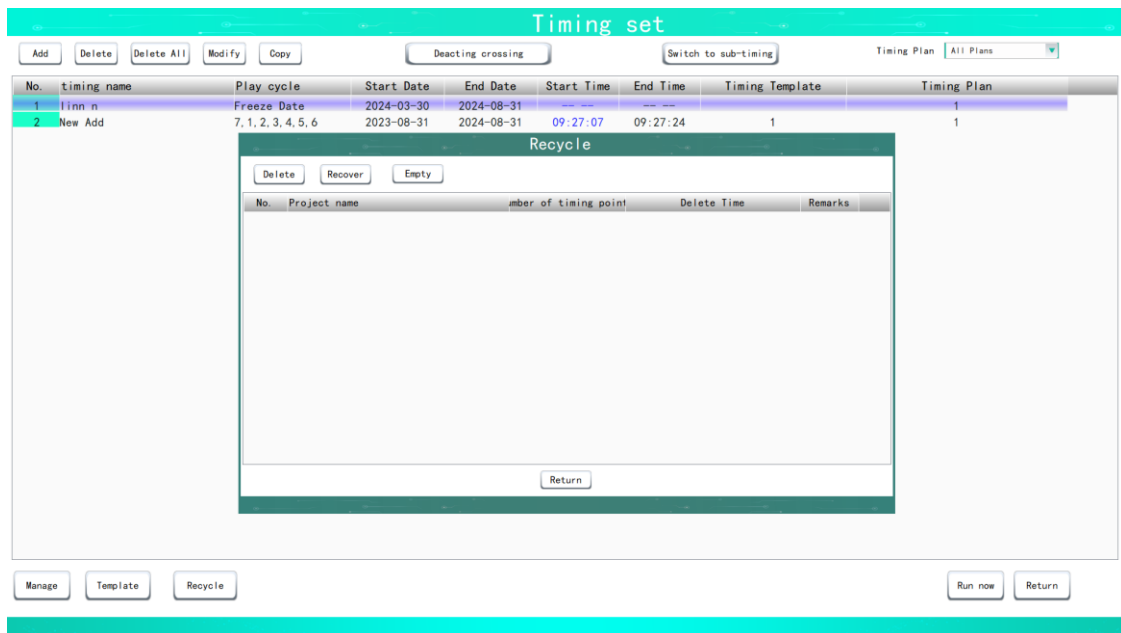

4.3.11 Browse Timing Point Information

Click the “Today Preview” button in the timing point column to enter the timing point browsing interface, as shown in the figure below.

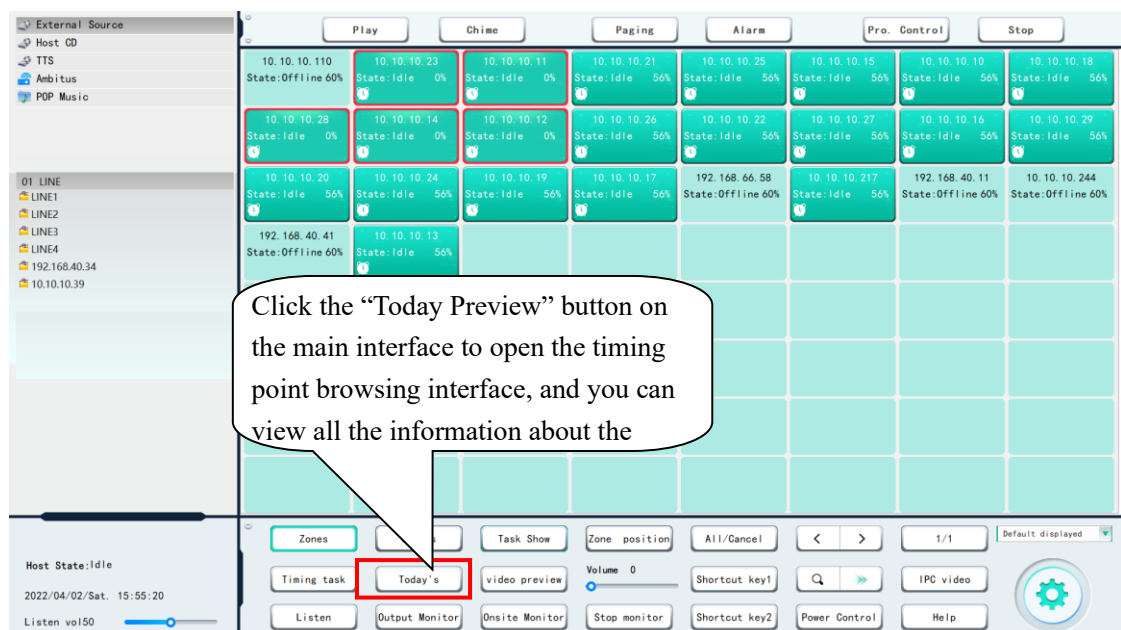

Today Preview Interface

On this interface, you can view all the timing points of the day. Click the “Detailed Information” button in the figure below to view the timing point information, including the execution of each timing point, etc. You can also switch the state “Disable & Enable” of a certain timing point on this interface. For example, if you need to cancel

the timing point of outdoor radio gymnastics on a rainy day, you can select the timing point where the radio gymnastics is located, and click the “Disable & Enable” button once, and then you can view the state displayed as “Disabled”. The disabled timing point will be banned on the same day and will be continued the day after tomorrow.

Check Today's Timing Point							
No.	Name	Play Cycle	Start Date	End Date	Start Time	End Time	State
32	timing 7	7, 1, 2, 3, 4, 5, 6	---	---	08:45:15	08:55:06	Done
33	timing 7	7, 1, 2, 3, 4, 5, 6	---	---	08:45:15	08:55:06	Done
34	timing 7	7, 1, 2, 3, 4, 5, 6	---	---	08:45:15	08:55:06	Done
35	timing 7	7, 1, 2, 3, 4, 5, 6	---	---	08:45:15	08:55:06	Done
36	timing 7	7, 1, 2, 3, 4, 5, 6	---	---	08:45:15	08:55:06	Done
37	timing 7	7, 1, 2, 3, 4, 5, 6	---	---	08:45:15	08:55:06	Done
38	timing 7	7, 1, 2, 3, 4, 5, 6	---	---	08:45:15	08:55:06	Done
39	timing 7	7, 1, 2, 3, 4, 5, 6	---	---	08:45:15	08:55:06	Done
40	timing 7	7, 1, 2, 3, 4, 5, 6	---	---	08:45:15	08:55:06	Done
41	timing 7	7, 1, 2, 3, 4, 5, 6	---	---	08:45:15	08:55:06	Done
42	timing 7	7, 1, 2, 3, 4, 5, 6	---	---	08:45:15	08:55:06	Done
43	timing 7	7, 1, 2, 3, 4, 5, 6	---	---	08:45:15	08:55:06	Done
44	timing 7	7, 1, 2, 3, 4, 5, 6	---	---	08:45:15	08:55:06	Done
45	timing 7	7, 1, 2, 3, 4, 5, 6	---	---	08:45:15	08:55:06	Done
46	timing 7	7, 1, 2, 3, 4, 5, 6	---	---	08:45:15	08:55:06	Done
47	timing 7	7, 1, 2, 3, 4, 5, 6	---	---	08:45:15	08:55:06	Done
48	timing 7	7, 1, 2, 3, 4, 5, 6	---	---	08:45:15	08:55:06	Done
49	timing 7	7, 1, 2, 3, 4, 5, 6	---	---	08:45:15	08:55:06	Done
50	timing 1	7, 1, 2, 3, 4, 5, 6	---	---	12:20:50	13:06:01	Not executed
51	1	Everyday T. Point	2021-07-06	2022-07-06	13:53:18	14:46:56	Not executed
52	1	Everyday T. Point	2021-07-06	2022-07-06	13:53:18	14:46:56	Not executed

Details Disable&Enable Back

Regular: Today Timing Point Viewing Interface

Today's timing view											
No.	timing name	Sub Timing Point N	Play cycle	Start Date	End Date	Start Time	End Time	State	Affiliated Plan	Template	Songs and Device State
1	time1	1	7, 1, 2, 3, 4, 5, 6	---	---	15:17:25	15:17:42	Undo	admin	1	Normal State
2	New Add	1	7, 1, 2, 3, 4, 5, 6	---	---	17:39:48	17:40:05	Undo	admin	1	Normal State

Detailed Enable& Disable Return

Campus: Today Timing Point Viewing Interface

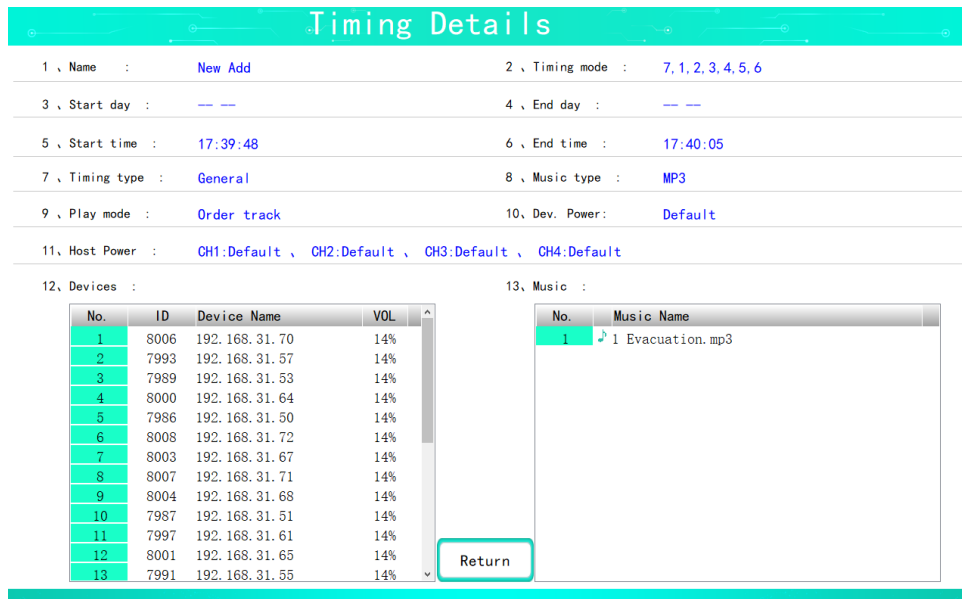

Campus: Today Timing Point Details Interface

4.3.12 Video Preview

Click the "Video Preview" button to enter the interface as shown below, you can view the video of the area monitored by the partition with built-in camera in real time (the "📹" icon will appear in the partition). In the host, the monitoring partition can be paging, alarming, IPC preview (that is, to view the external camera surveillance video) and volume adjustment, click the "stop" button, partition can perform the next task, click the "Zoom In & Out" button, you can zoom in and out of the selected video.

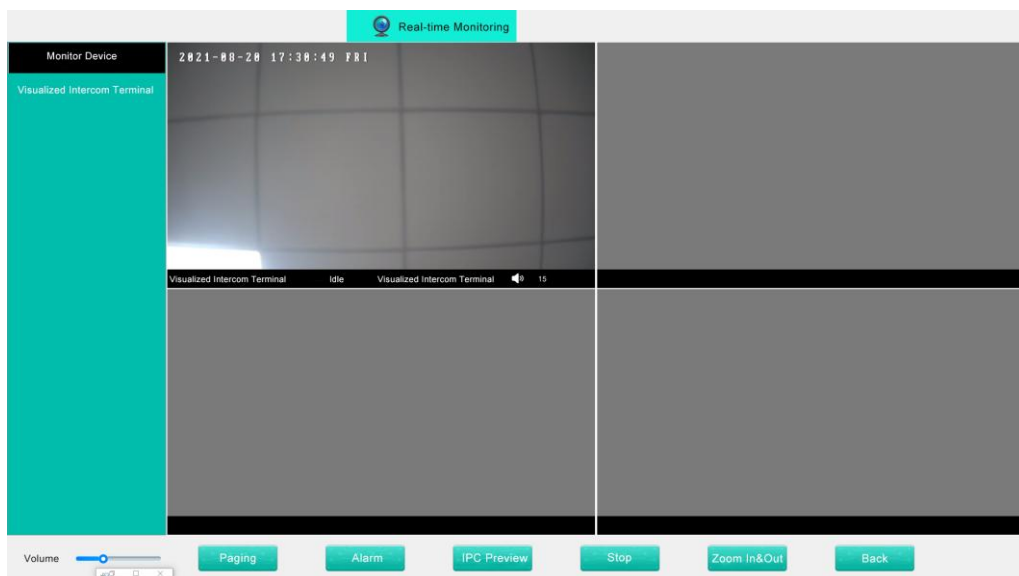

Video Preview Interface

4.3.13 Adjust Zone Volume

When adjusting the zone volume, first select the zone to be adjusted or select "All Zones" (the zone button turns red to indicate that it is selected), and then adjust the volume in the "Terminal Volume" column. When adjusting,

click and slide the fader to the appropriate position to complete the operation, as shown in the figure below.

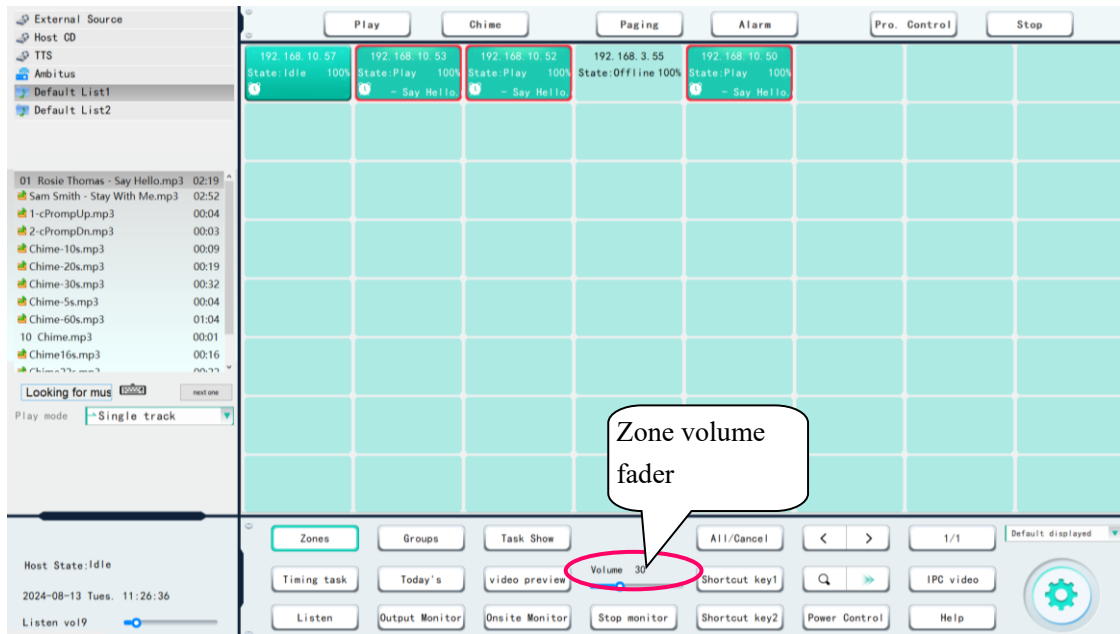

Adjust Volume Interface

4.3.14 IPC Video Preview

Click the "IPC Video Preview" button to enter the following figure interface, you can view the surveillance video with external camera partition in real time, click "Back" after setting it to return to the previous interface.

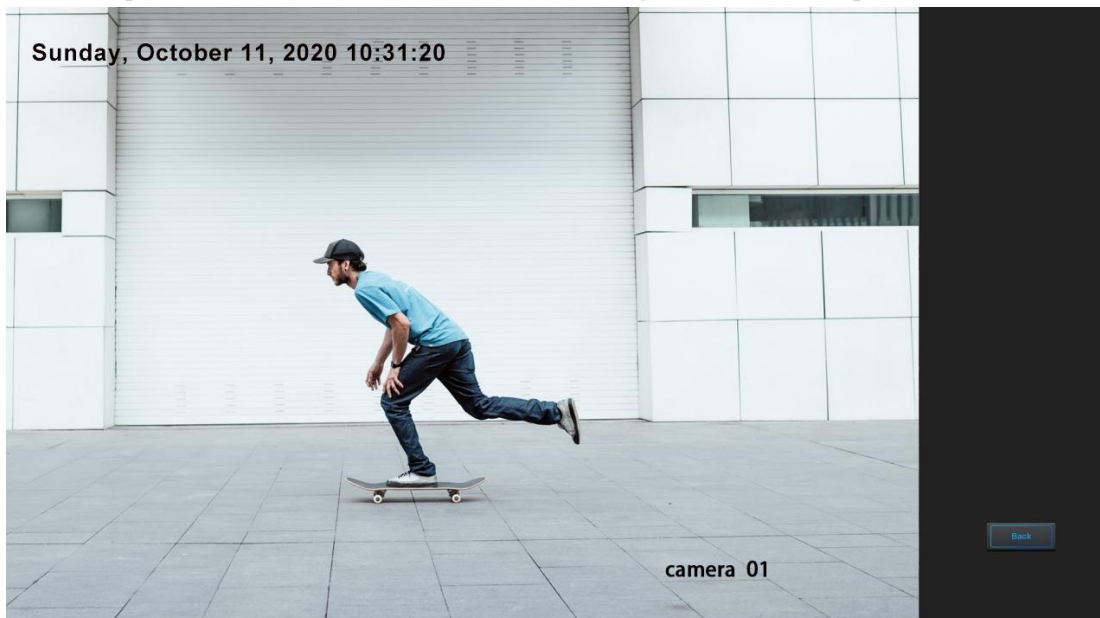

IPC Video Preview Interface

4.3.15 Program Pre-listening

When pre-listening the program in the program source, select the program you want to pre-listen to in the audio source list area, and then click the "Pre-listen" button in the "Program Pre-listening" column to start pre-listening to the selected program, and you can adjust the pre-listening volume in the lower left corner of the main interface,

and click the “Stop” button to stop it.

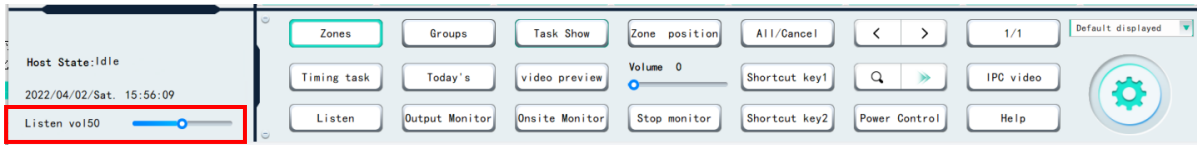

4.3.16 Zone Monitoring

When operating “Output Monitor” and “Live Monitor”, first set the device to be monitored in the “Monitor Device Settings” in the general settings, and click “Save” to finish the operation, as shown in the figure below. If you want to cancel the monitoring of this zone, you can select the zone and click the “Cancel Monitoring” button.

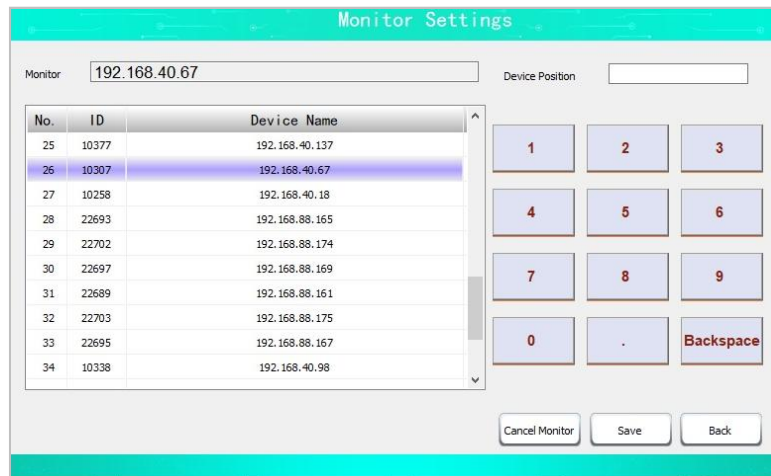

Monitor Device Settings Interface

Output Monitor:

Through the output monitor, you can clearly know all the working status of the terminal.

The monitor device must be in an idle state, and the monitored device is in a working state. First, select a fixed idle monitor speaker in the “Monitor Device Settings” item of the system settings, and then select the zone of the monitored device in working state on the main interface to monitor the content playing in the zone through the monitor speaker.

Tips: Only one zone can be monitored at a time, and multiple zones cannot be monitored at the same time. You can switch to monitor different zones, as shown in the figure below.

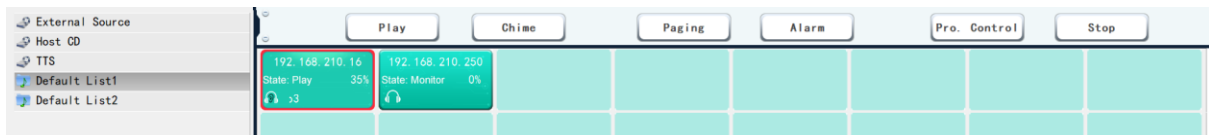

Output Monitor Interface

Live Monitor:

Through the live monitor, you can know the actual working status of the terminal.

The monitor device must be in an idle state, and the monitored device is in a working state. First, select a fixed idle monitor speaker in the “Monitor Device Settings” item of the system settings, and then select the zone of the monitored device in working state on the main interface to monitor the content playing in the zone through the monitor speaker.

Tips: Only one zone can be monitored at a time, and multiple zones cannot be monitored at the same time. You can switch to monitor different zones, as shown in the figure below.



Live Monitor Interface

4.3.17 Shortcut Key 1 & Shortcut Key 2

Before using the “Shortcut Key 1” and “Shortcut Key 2”, first click “Shortcut Key Settings” in the general settings of the system settings to set the operation functions and the terminal devices of “Shortcut Key 1” and “Shortcut Key 2”. For the specific operation method, please refer to the operation instructions on “Shortcut Key Settings”; then directly click “Shortcut Key 1” or “Shortcut Key 2” on the main interface to perform shortcut key function operations, as shown in the figure below.



Shortcut Key Interface

4.3.18 Power Control

As shown in the figure below, the button in the “Timing Point Control” column is the timing point to control the 4-channel power switch of the host, “ON Program Control” means that the timing point can control the 4-channel power supply of the host, and “OFF Program Control” means that the timing point cannot control the 4-channel power supply of the host. CH1-CH4 is the 4-channel power supply of the host.

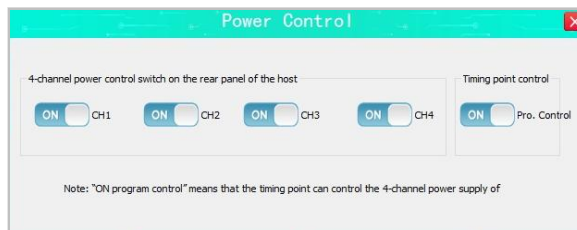

Power Control Interface

4.3.19 Broadcast Priority

When playing background music to the zone, signals such as paging, alarm, chime, and timing point are often inserted. According to actual needs, the system set the priority of those signals by default, as shown in the figure below:

Host paging → Host alarm → Fire alarm → Paging between devices → Playing chime → Timing program → Broadcasting program → On-demand program

When a high-priority signal breaks in, the low-priority signal enters the waiting state or stops. After the high-priority signal ends and exits, the low-priority signal can continue, and the audio signals of the same priority level cannot interrupt each other.

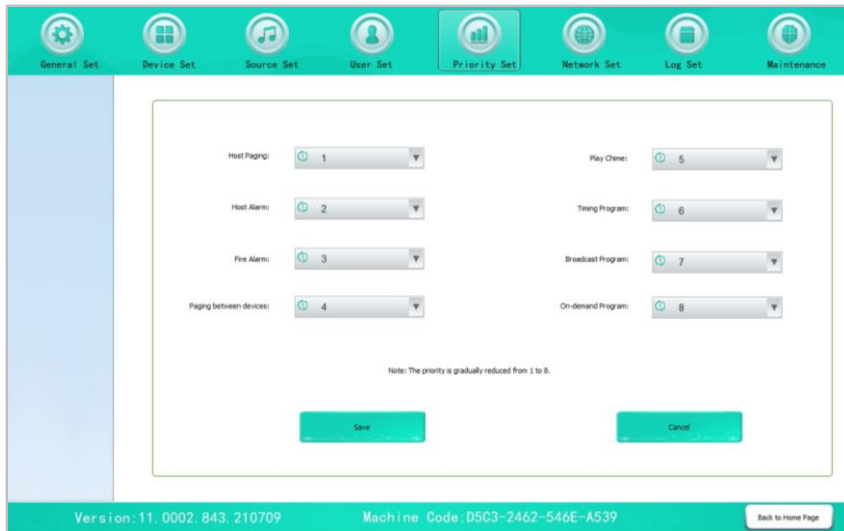

The screenshot displays a web-based configuration interface for a system. At the top, a teal navigation bar contains eight menu items: General Set, Device Set, Source Set, User Set, Priority Set (which is highlighted), Network Set, Log Set, and Maintenance. The main content area is a white box with a light blue sidebar on the left. It features two columns of settings, each with a circular refresh icon and a dropdown arrow. The left column includes: Host Paging (1), Host Alarm (2), Fire Alarm (3), and Paging between devices (4). The right column includes: Play Chain (5), Training Program (6), Broadcast Program (7), and On-demand Program (8). A note below the settings states: "Note: The priority is gradually reduced from 1 to 8." At the bottom of the settings box are two teal buttons: Save and Cancel. The footer of the interface is a teal bar containing the text "Version: 11.0002.843.210709", "Machine Code: D5C3-2462-546E-A539", and a "Back to Home Page" button.

Setting	Value
Host Paging	1
Host Alarm	2
Fire Alarm	3
Paging between devices	4
Play Chain	5
Training Program	6
Broadcast Program	7
On-demand Program	8

Note: The priority is gradually reduced from 1 to 8.

Save Cancel

Version: 11.0002.843.210709 Machine Code: D5C3-2462-546E-A539 Back to Home Page

Priority Settings Interface

V. System Settings

Click the “Settings” button in the lower right corner of the main interface to enter the system settings interface, as shown in the figure below.

All settings in the network public address system should be made via this window, including general settings, device management, sound source management, user management, priority settings, network settings, log management, and system maintenance.



System Settings Interface

5.1 General Settings

1) Time Settings:

The method to modify the system time is as follows: First select the option that needs to be modified among the year, month, day, hour, minute, and second, and then press the “+” and “—” buttons on the right side of the time bar to adjust the number, and then click the “Update” button to complete the operation.

2) Security Settings:

Tick the corresponding gray box in front of “Password is required to enter settings” or “Password is required after screen saver”, and the functions of the corresponding options will take effect. For example, after ticking “Password is required to enter settings”, click the icon “System Settings” on the main interface, and then the input password dialog box will pop up as shown in the figure below:



Input Password Interface

3) Time Calibration, Language Settings, Transit Server Settings

- Time calibration:

Click the small gray inverted triangle icon to select the device calibration time, with the range of 1h-24h.

- Language settings:

Select the language type in the language settings bar, and restart the server to take effect.

- Host Backup Settings:

- When you need to enable the backup function, you must tick in front of the “Main server” of the main server, and click the “OK” button in the pop-up dialog box, and the item of the standby server cannot be ticked. The device with “Main server” ticked is the main server, and the other one is the standby server.
- Tick in front of the “Startup” of the main server to pop up the backup sending terminal interface as shown below. If you tick in front of the “Startup” of the standby server, it will pop up the backup receiving terminal interface. Click “Keyboard” to set the main/standby server IP address corresponding to the server IP, and then click “Start” to start the backup function of the main/standby server. If tick the item of auto connection to the server, the current record will be saved automatically when you open it next time; click “Clear Log” to clear the current log record.

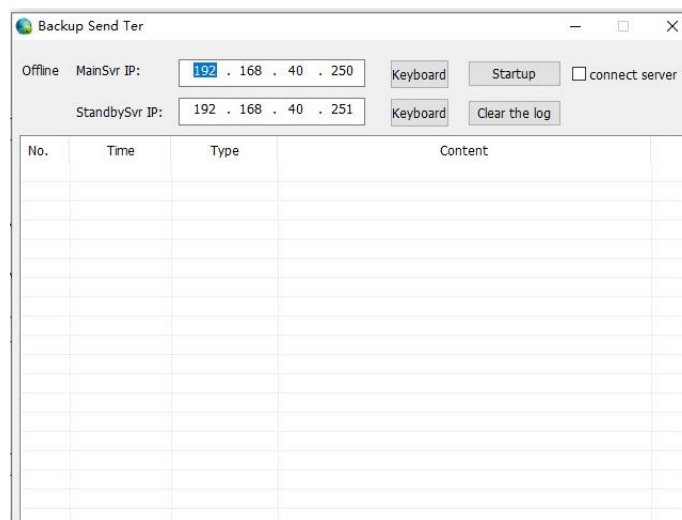

Backup Sending Terminal Interface

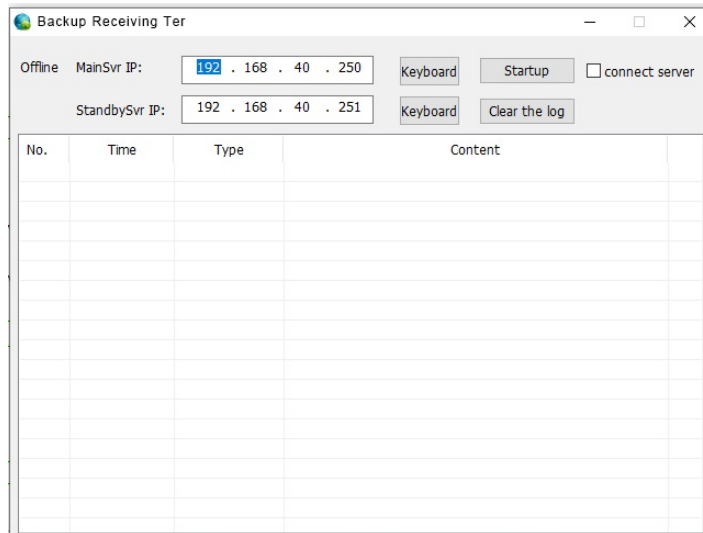

Backup Receiving Terminal Interface

- Transit server settings:

Tick the box to pop up the interface as shown below. If tick the box in front of “Auto connection to the server”, the current record will be saved automatically when you open it next time. If tick the box in front of “Auto startup at boot”, the transit server will be turned on automatically when you turn it on next time. Click “Clear Log” to clear the current log record.

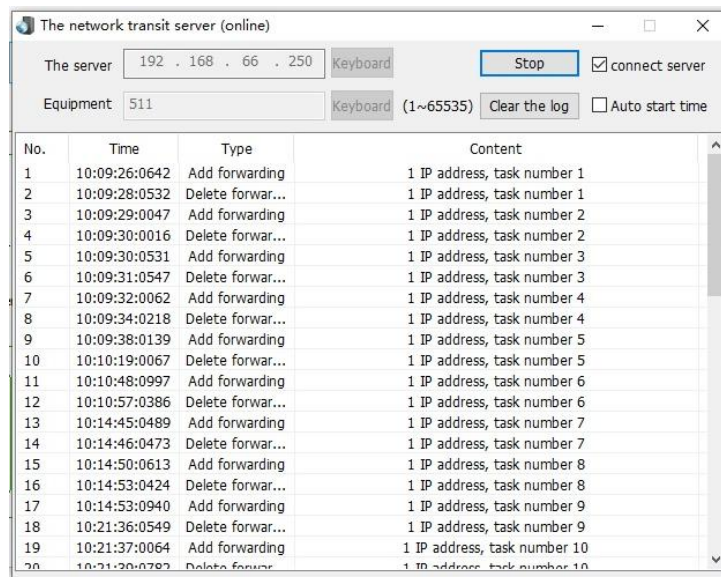

Network Transit Server Interface

4) Other Settings

- Shortcut key settings:

Find “Shortcut Key Settings” in the “Other Settings” column of the “General Settings” interface, and click “Shortcut Key Settings” to enter the “Shortcut Key Settings” interface and perform operations as shown in the figure below. The specific steps are as follows:



Shortcut Key Settings Interface

1. Select the “Shortcut Key 1” or “Shortcut Key 2” and click Modify Function, and the “Shortcut Key Editing” interface will pop up as shown in the figure below.
2. Click “Select Function” → select “Play Mode” → click “Add Device” to enter the add device interface to set the terminal device to be played by a shortcut key; click “Add Song” to enter the “Add Audio Source” interface, select the music catalog and then select the song, click “OK” to jump back to the “Shortcut Key Editing” interface, click “Save” to complete the editing operation.

Click the “Modify Function” button in the “Shortcut Key Settings Interface” in the above figure to modify the functions of the shortcut operation (such as host paging, alarm, playback, etc.); click “Modify Name” to modify the display name of the shortcut key on the host interface; click “Delete Function” to delete the functions of the shortcut key, that is, this button is not displayed on the main interface.

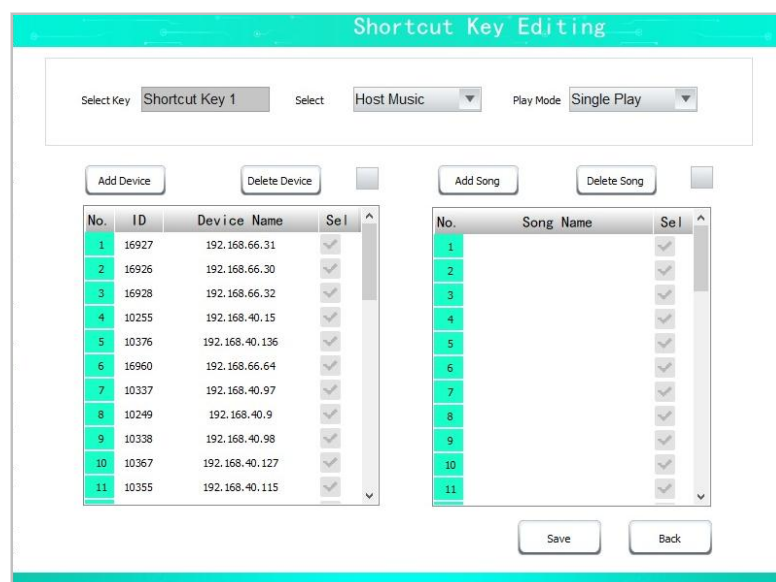

Shortcut Key Editing Interface

- Monitor device settings:

Select a device number as the monitor device, and click Save, as shown in the figure below. (refer to the instructions on zone monitoring on the main interface)

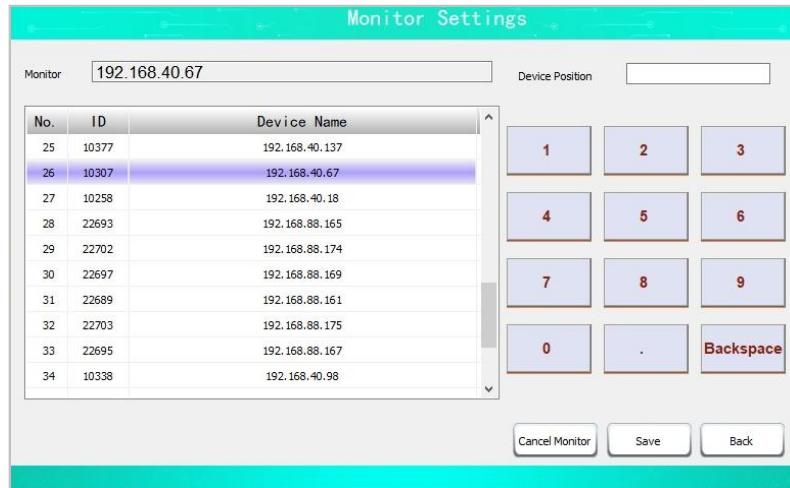

Monitor Settings Interface

- GPS settings:

Enter the device IP in the GPS time calibration device setting column and click Save.

- Eject CD-ROM:

Click the “Eject CD-ROM” button to eject the host CD-ROM intelligently without disassembling the device.

- Restart system:

Click “Restart System” and click “OK” in the prompt box to restart the host, as shown in the figure below.

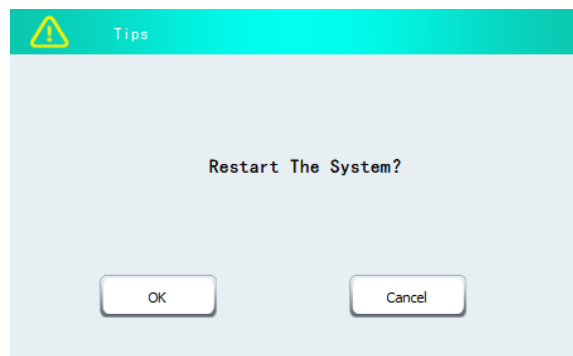

Restart Host Interface

- Register WEB:

Click “Register WEB”, enter the register code provided by our company, as shown in the figure below, and click “Register”.

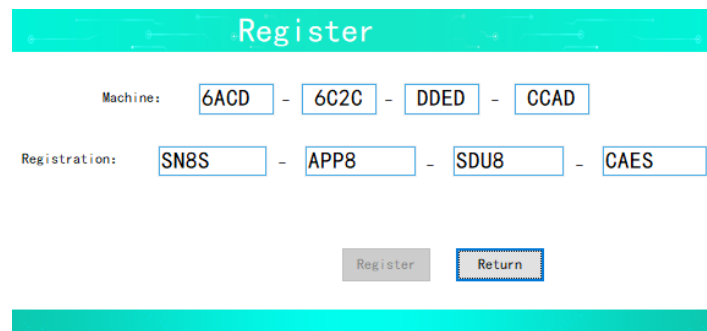

- Shut Down System:

Click “Shut Down System” and click “OK” to shut down the server, as shown in the figure below.



Shut down System Interface

- Register SDK:

Click the “Register SDK” button, enter the registration code provided by our company, as shown in the figure below, click “Register”.

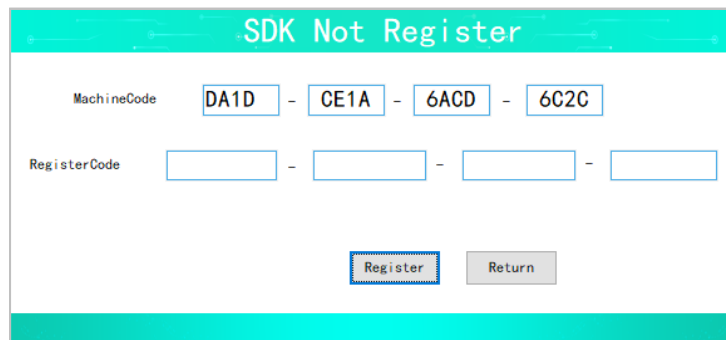

Register SDK Interface

- Timing ON/OFF switch:

Follow the steps shown below, the user can set the switch time of the device according to the work needs, and save it after setting.

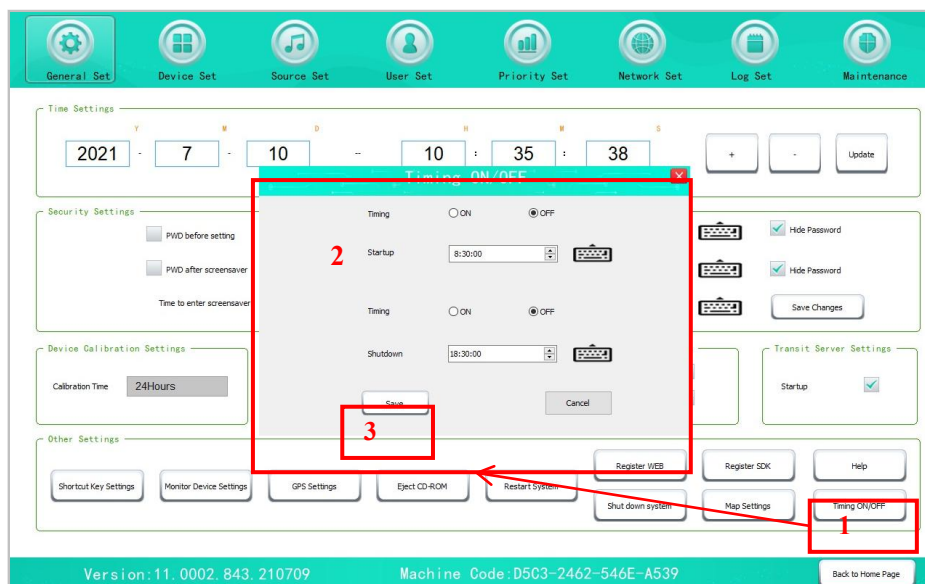

Timing ON/OFF Switch Interface

- Map settings

Click the “Map Settings” button to pop up the corresponding setting interface as shown in the figure below. The different patterns of the zones in the list on the left indicate that different tasks are performed. At the top of the interface is the map operation toolbar:

Select/Framed select: Select the device zones in the list and map on the left side of the interface.

Add: Select the device number on the left, and then click the appropriate location on the map to mark the device to the corresponding location.

Delete: Delete the device mark in the map.

Grip: Can move the map up, down, left and right.

Zoom in/out: Can zoom in/out to view the map.

Reset: Clear the device number in the map with one click.

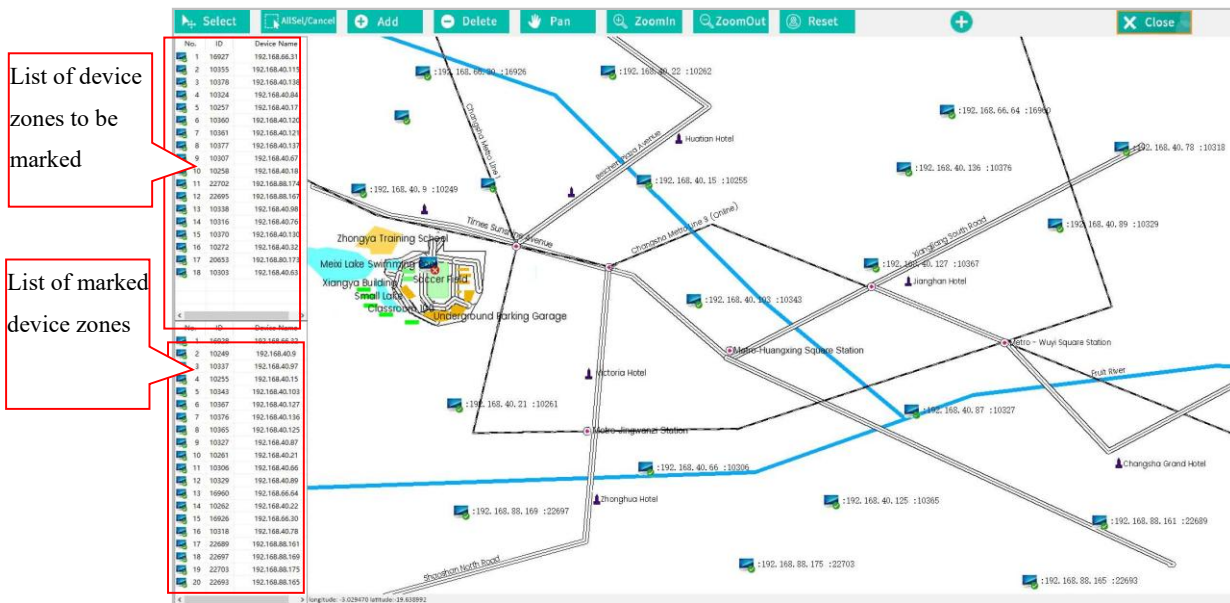

Map Settings Interface

- Help:

Click “Help” to browse the help document, and the user can click on the help document to guide the operation if he has no idea to operate.

As shown in the figure below: the left is the contents bar, and the right is the content bar. Find the help function item you want to view in the contents bar, click it to jump to the corresponding content; click the “Back” button in the lower right corner to return to the host operation interface. (Please refer to the manual of the machine)

5.2 Device Management

5.2.1 Device Information

(1) Delete Device Information

Select the device to be deleted, click “Delete” and “OK” to delete successfully; as shown in the figure below.

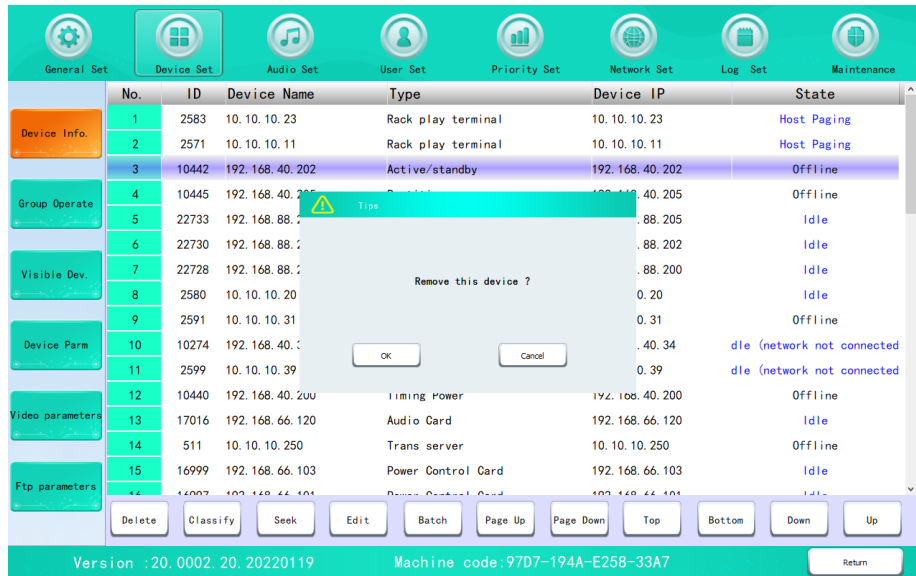

Device Information Interface

(2) Classified Display

Click “Classified Display” to enter the device search interface. Through this function, you can display devices by device type and status. You can also input device name, device number or device IP to accurately filter devices as shown in the figure below.

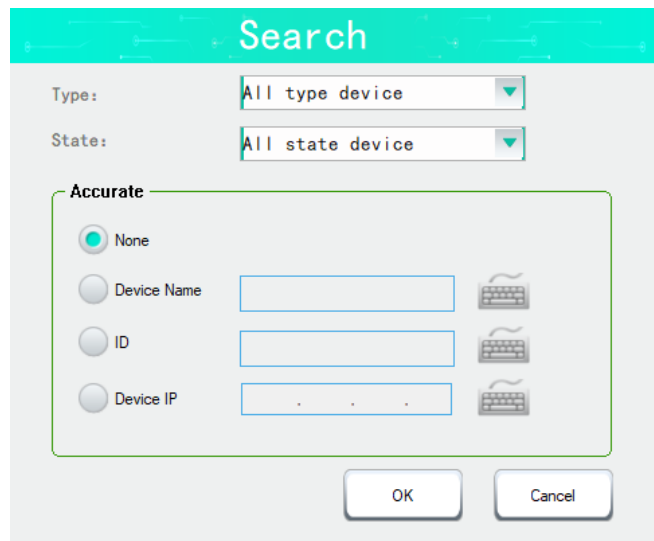

Classified Display Interface

(3) Device Positioning

Enter the device number to directly locate the sorting position of the device, and it is convenient to check the device status as shown in the figure below.

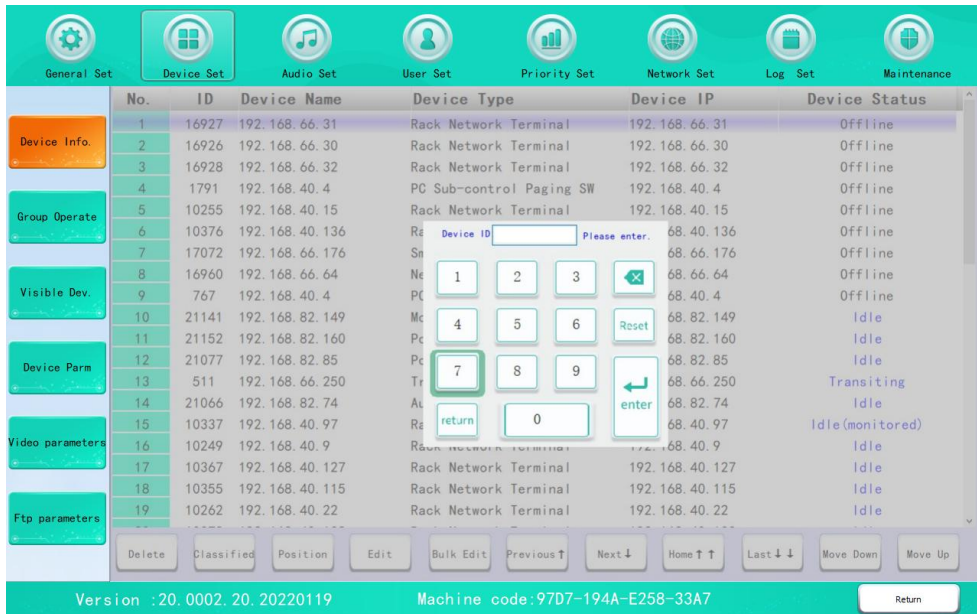

Device Positioning Interface

(4) Edit

Through the “Edit” function, you can modify the terminal number, version, terminal type and terminal name, select the data transmission mode as unicast or multicast, control the switch of the transit server, streaming server, and upload streaming media. When the streaming media server and uploading streaming media items are enabled, the corresponding streaming media device number and FTP server account can be selected. And you can also control the output volume and priority.

- When selecting a visualized paging station for editing, click “Displayable Devices” to set whether the zones or groups on the main interface of the smart paging station are displayed. The selected devices will be displayed on the main interface of the paging station, and the unselected device will not be displayed on the main interface of the paging station, which is configured through the buttons <<< and >>>, as shown below.

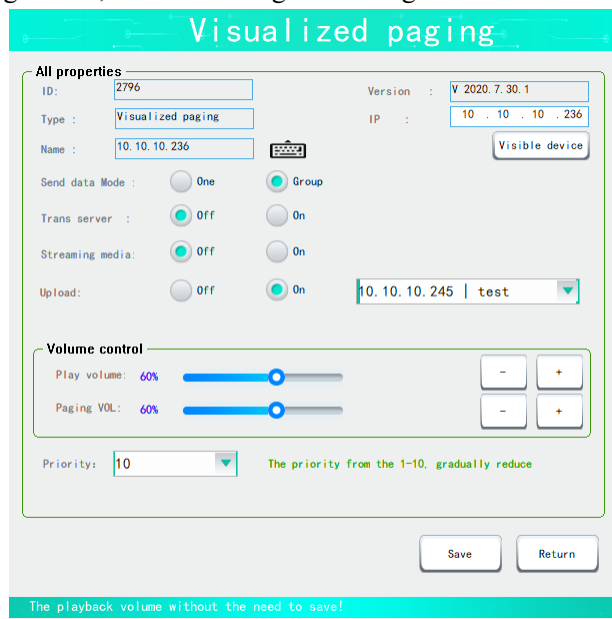

Visualized Paging Station Editing Interface

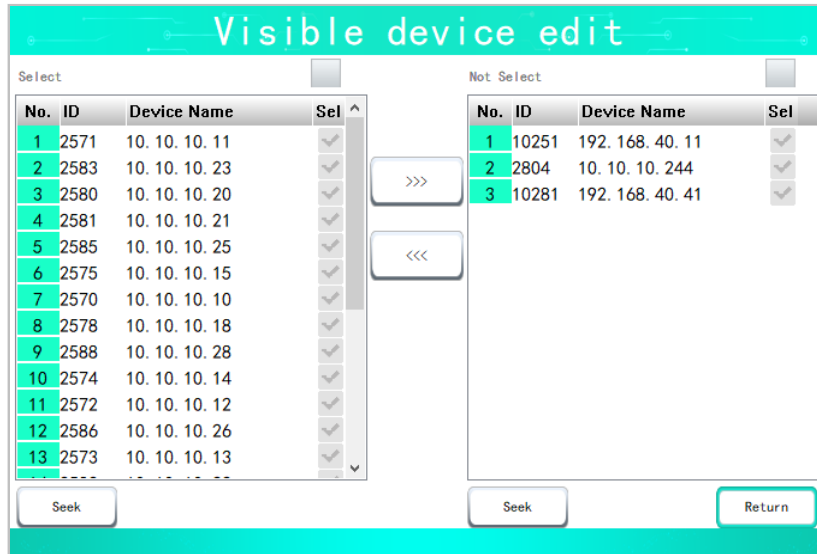

Displayable Devices Editing Interface

- When selecting a networked console for editing, click "Visible Devices" to set whether the partitions or groups on the main interface of the networked mixer are displayed. The selected devices will be displayed in the main interface of the networked mixer, and unselected devices will not be displayed in the main interface of the networked mixer, configured by <<< and >>> buttons. As shown in the figure below;

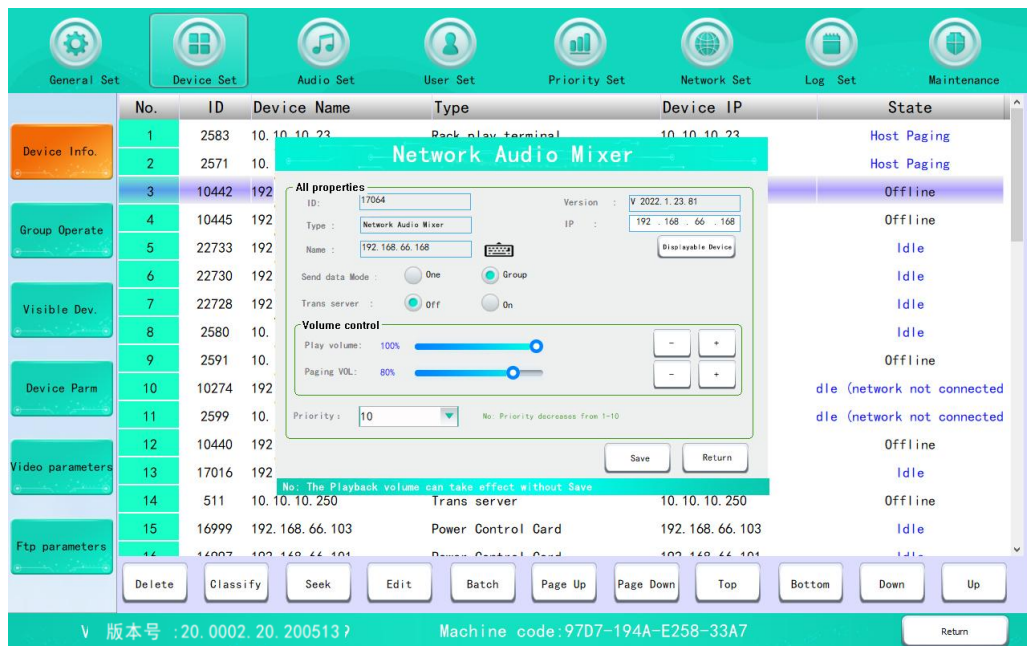

Mixer Editing Interface

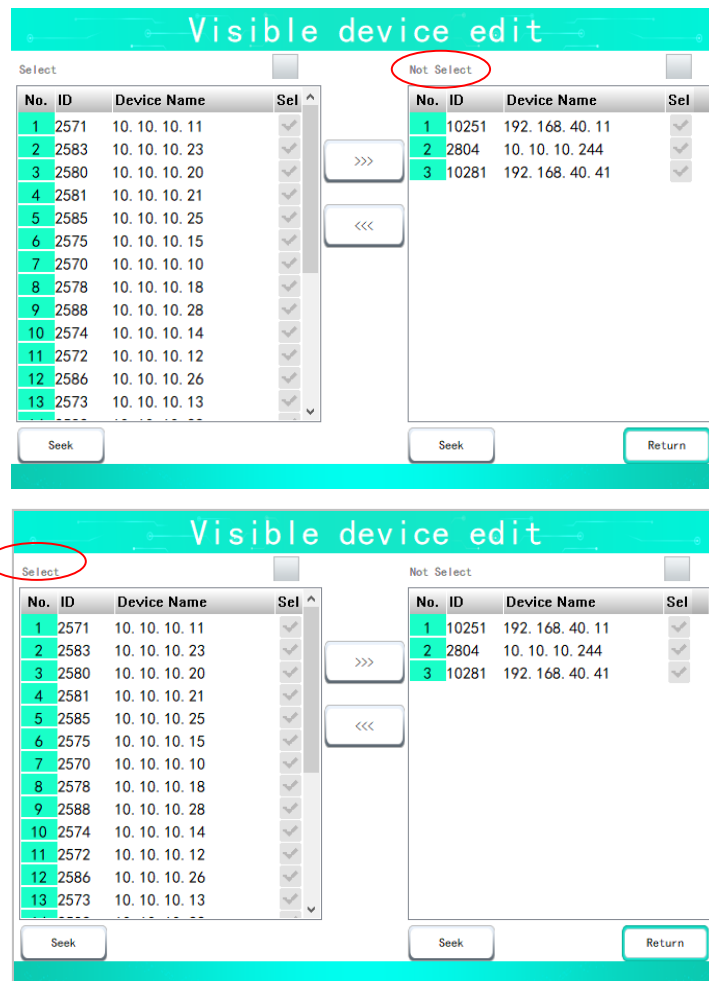

Displayable Devices Editing Interface

- When selecting "Dual-use visualized intercom terminal" for editing, click the "Call for help" button to set the visualized paging controller that receives the help signal/business consultation signal when the visualized intercom terminal initiates emergency call for help. Click the "Bind IPC" button, and enter the user name, password, IP address, port and other information of the external surveillance camera in the pop-up interface to bind the external surveillance camera to this device terminal, and support Hikvision and Dahua AI camera linkage. (Please refer to the manual of dual-use video intercom terminal for specific settings.)

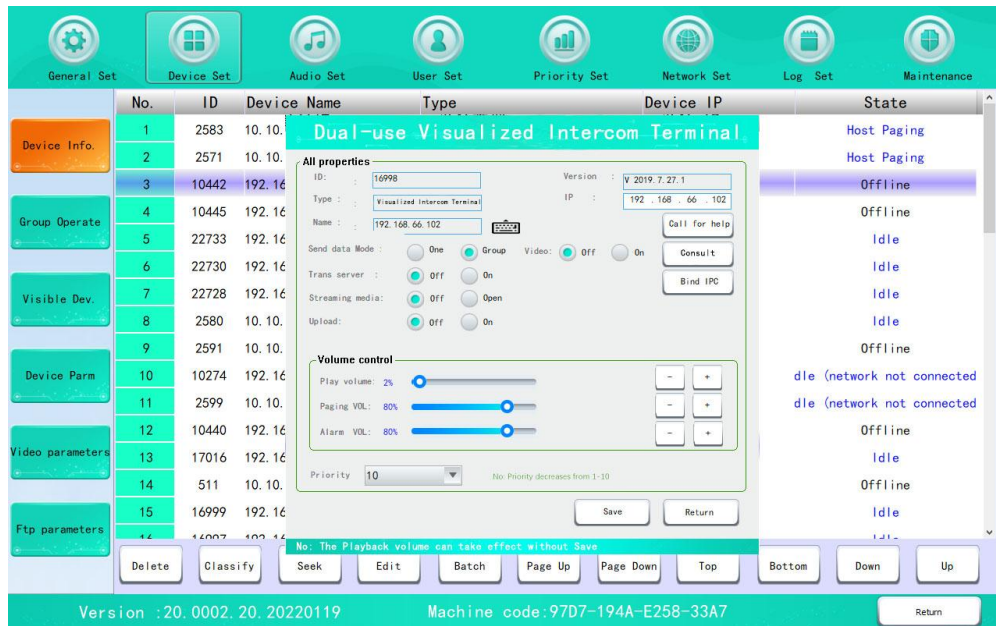

Dual-use Visualized Intercom Terminal Editing Interface

- (1) Terminal Types: the device is a dual-use video intercom terminal, the device type will be automatically displayed and cannot be changed in the host.
- (2) Name: It is the default, you can edit the name of the terminal as needed.
- (3) IP: The IP address of the device will be automatically displayed in the host, which can be changed in the host software's "Settings" -> "System Maintenance" -> "Device Maintenance" -> "Modify IP", or it can be changed in the terminal device
- (4) Transit Server: If the terminal and the requested device are not in the same network segment or the network cannot meet the condition of data bidirectionality and need to enable the transit server for the device, you can enable the transit server on the intercom extension controller setting page for assistance.
- (5) Streaming Media Server / Upload Streaming Media: You can choose whether to enable the streaming media server and upload audio and video streams to the streaming media as required.
- (6) Priority: It is a user-defined item and can be set according to requirements. The priority of audio sources of the same type of equipment is gradually decreased from 1-10.
- (7) Call for Help: Click the "Call for help" button to set the intercom device of the dual-use video intercom terminal. The setting interface is as follows:

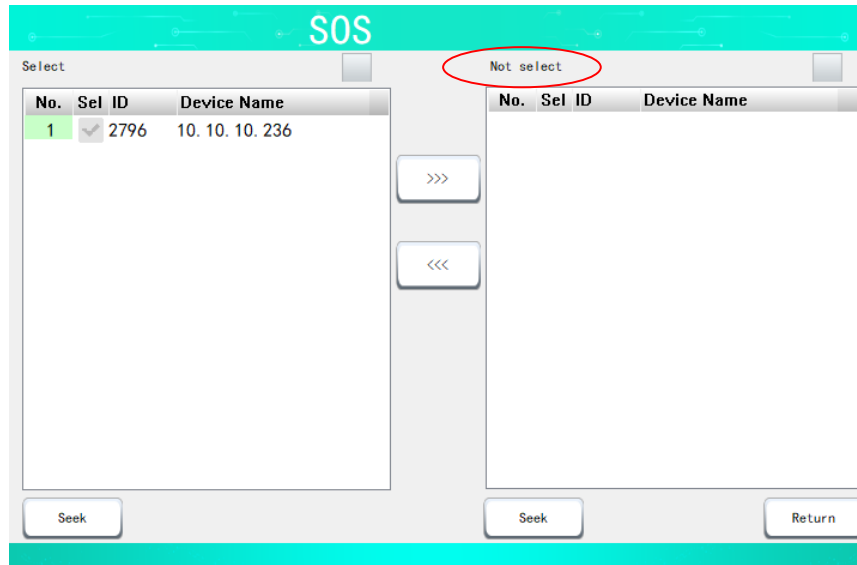

Move the device that needs intercom for help from the “Not select” intelligent paging station to the “Select” intelligent paging station list through the <<< button:

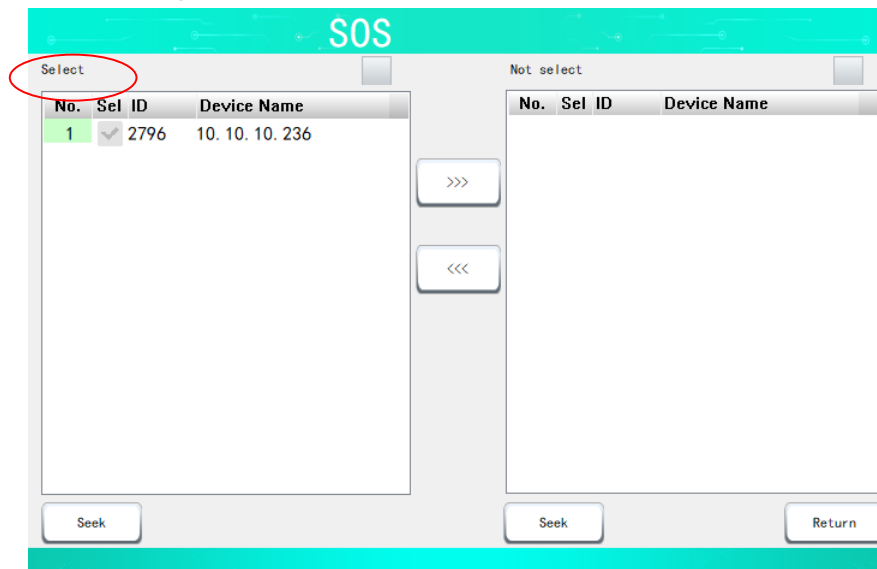

After selection, return to the dual-use video intercom terminal page, and click the save button to save. Please note that the modification can take effect only when the device is idle.

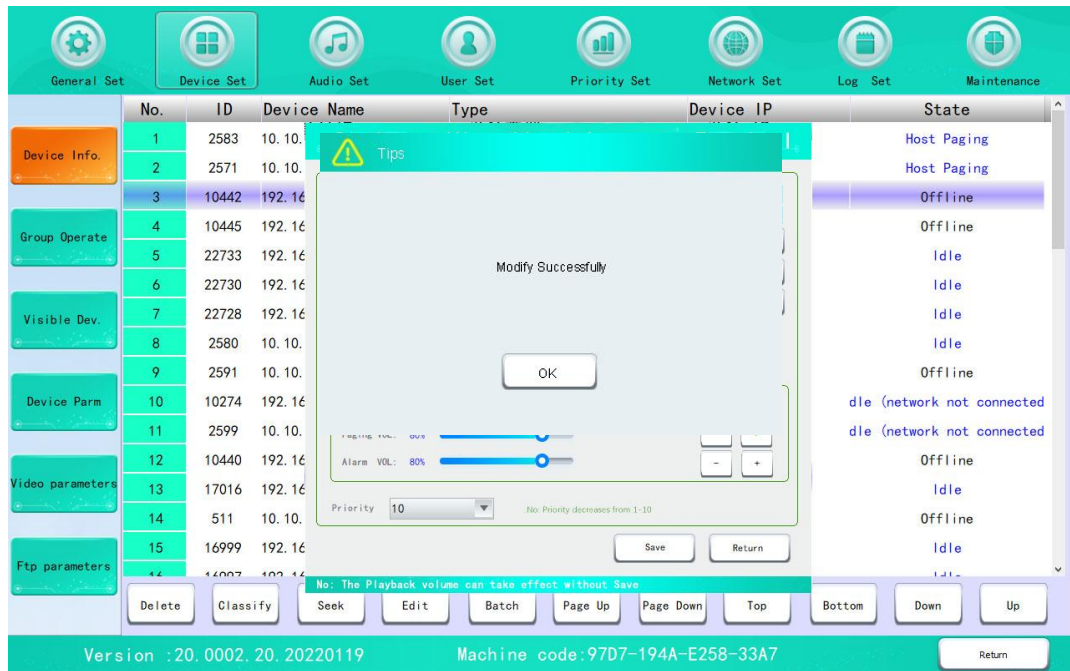

After adding the paging device for help intercom, press the call for help button on the terminal panel, the device will initiate an intercom request to the paging station device, and if the paging station device agrees to the intercom, the intercom for help can be performed. If the device is offline, it will prompt "offline", if the requested device has not agreed to the intercom, it will prompt "please wait", and if the requested device is busy, it will prompt "busy".

(8) Bind IPC: Click the "Bind IPC" button, enter the user name, password, IP address, port and other information of the surveillance camera in the pop-up interface. The main stream and sub-stream can be configured in the channel information, according to the configuration requirements of Hikvision and Dahua cameras; Click the "OK" button to bind the external surveillance camera to this terminal, select this terminal on the main interface of the host, and click the "IPC video" button to view the on-site surveillance video.

At present, the Network PA System only supports Hikvision cameras and Dahua cameras; After enabling the AI camera function, you can choose to enable the camera "Alert Detection" function and enter the TCP port (Dahua: 37777, Hikvision: 80000).

Bind IPC Interface

When adding an alarm sound source, first click the "..." three-dot button behind the warning sound source in the above picture to enter the interface as shown below, and then select the appropriate alarm sound to cooperate with the camera to realize the AI broadcast function.

It is recommended to set only one event per camera when making AI linkage settings.

➤ Hikvision Camera Linkage Settings:

After selecting the linkage Hikvision camera, click the "AI linkage settings" button in the "Bind IPC interface" to directly enter the camera web page in the browser, as shown in the figure below configuration interface, click "Configuration" - "Smart Event" - "Area Intrusion Detection" to enable event - "Draw Area" can freely draw the area, and then click Save to take effect.

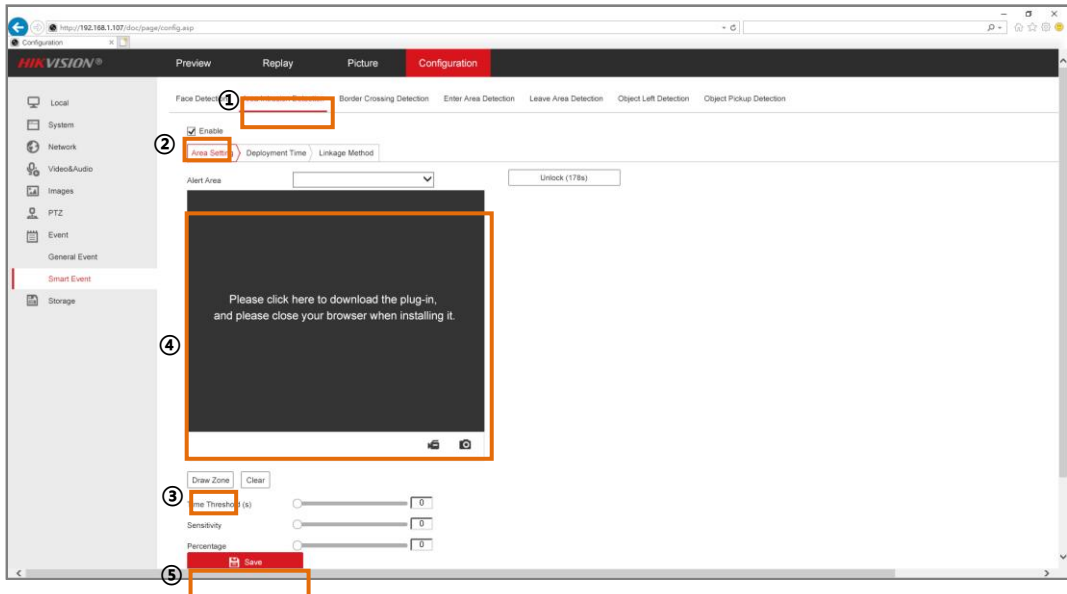

After clicking the "Linkage Mode" item and checking "Upload Center" to save, the area intrusion detection event will take effect;

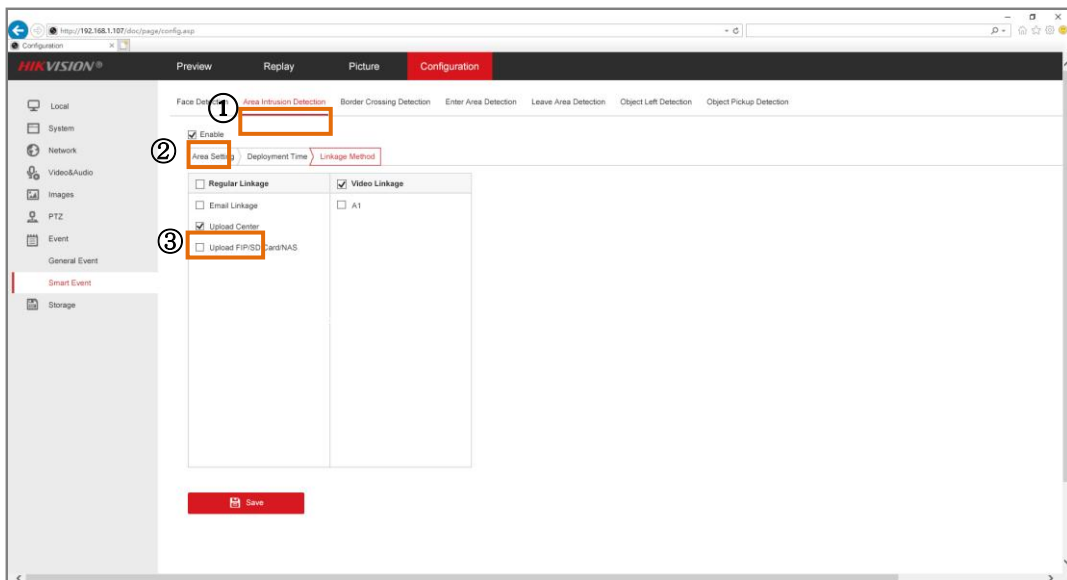

"Smart event" includes "Area intrusion" "Border crossing detection" "Enter area detection" and "Leave area detection" events, whose setting steps are same as above.

➤ Dahua Camera Linkage Settings

After selecting the linkage Dahua camera, click the "AI linkage settings" button in the "Bind IPC interface" to directly enter the camera web page in the browser, and enter the figure below through the "Settings" item:

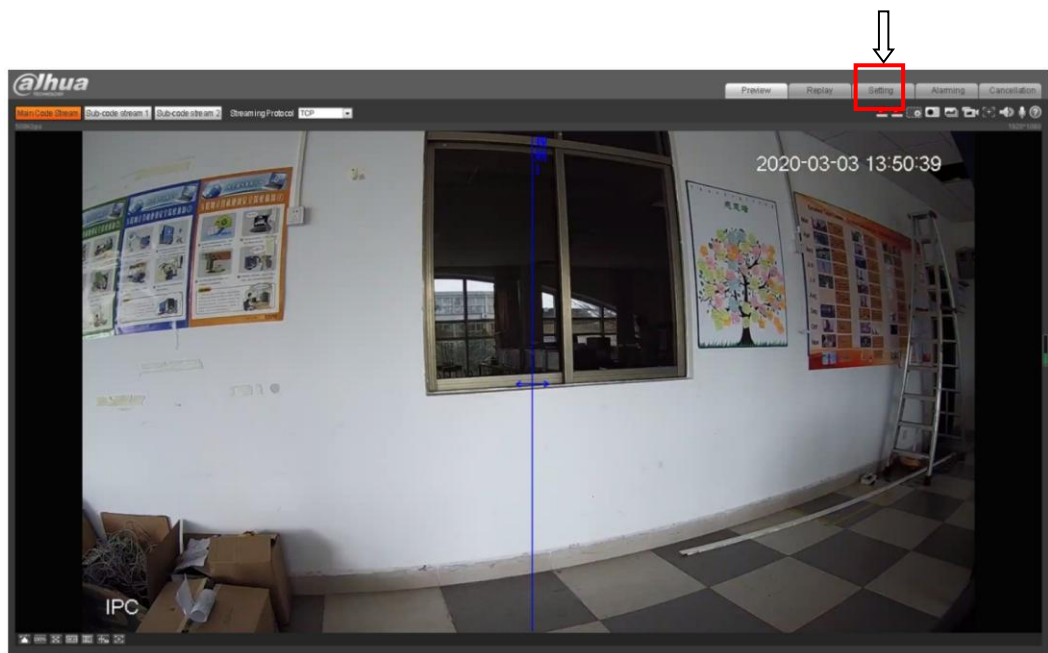

Select “General Behavior Analysis” - “Cross-line Intrusion” on the right side of the interface - Select event type, support “Cross-line Intrusion” and “Zone Intrusion”.

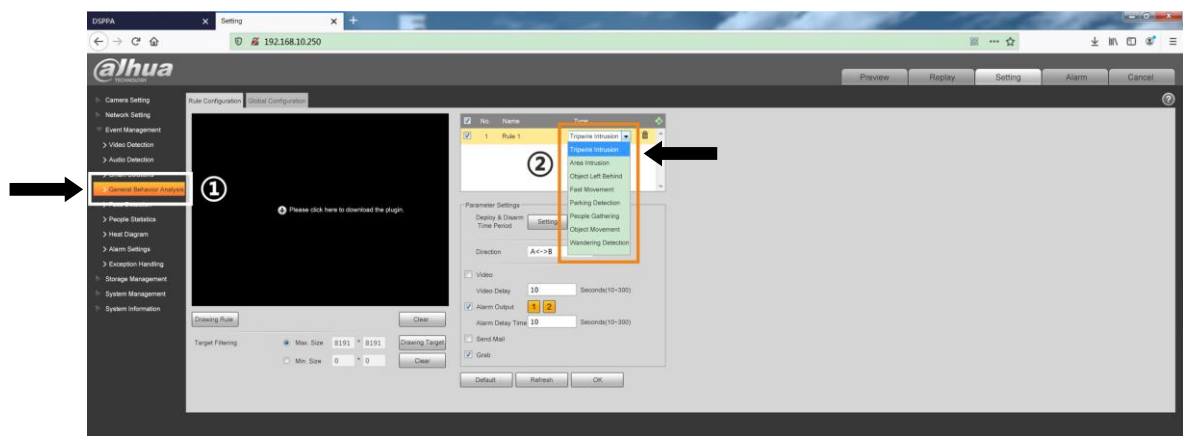

After completing the camera configuration, please check whether the server-side event configuration takes effect.

- When selecting a wireless microphone for editing, enter the interface as shown below:



- (1) Terminal type: This device is a wireless microphone, the device type will be automatically displayed in the host and cannot be changed on the host;
- (2) Name: Default, you can edit the name of the terminal as needed;
- (3) IP: The IP address of device will be automatically displayed in the host, and it could be changed on the "System maintenance, Modify terminal IP" of the host, or on the terminal.
- (4) Other parameters: It is a user-defined item and can be set according to requirements and needs.
- (5) Click "Wireless Remote Control Setting" to set the function of the remote control key. The setting interface is as follows:

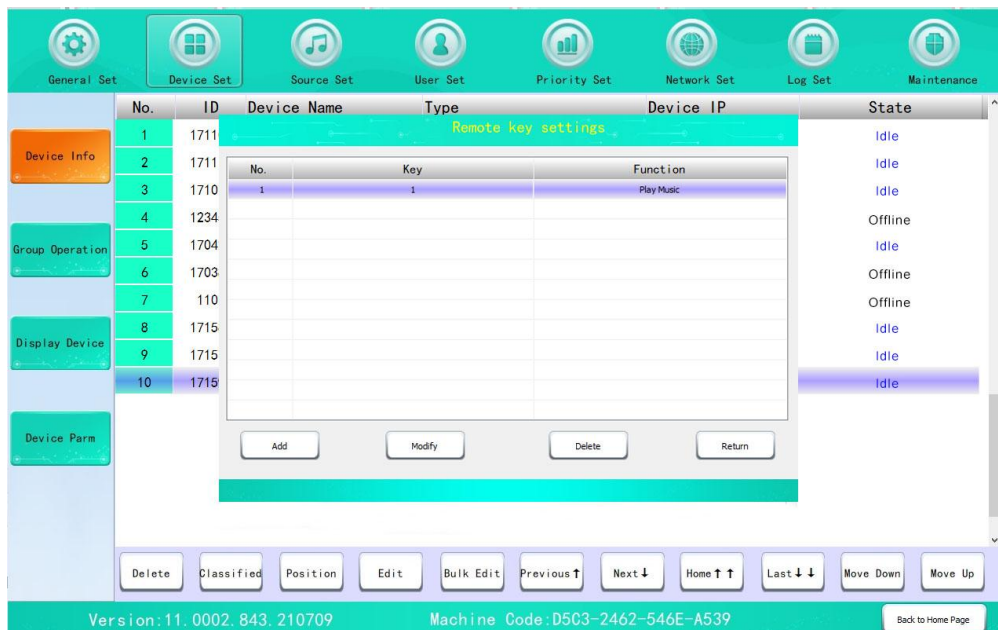

- 1) Click the "Add" button at the bottom of the left column to add key values and functions. The interface is as shown below:

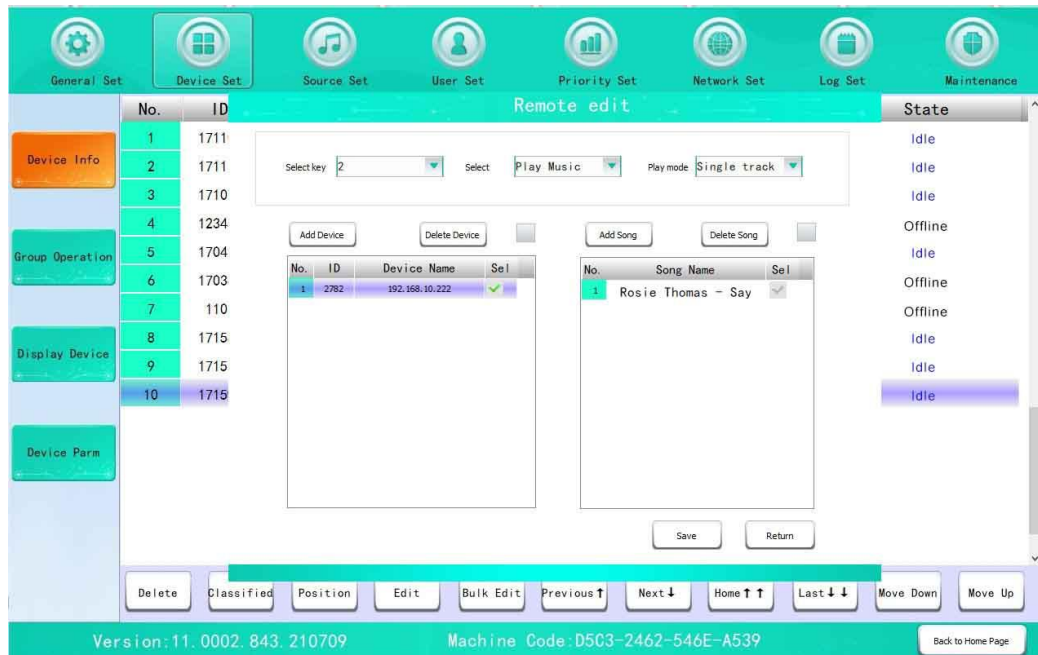

2) Users can choose to add and edit according to their own needs, and press "Save" after editing.

In the interface shown in the figure above, the upper part displays the function tasks and play modes to be edited, and the lower part displays the devices and songs to be added or deleted. The steps for editing a functional task are as follows:

① Select key value: The setting range of this key value is 1-9, which corresponds to 1-8+ keys on the remote control. For example, if the key value is set to "1", the "1" key operation of the remote control controls this function task.

② Select Function: There are six options in this item, including host playing music, host paging, volume +, volume - and stop. It is not recommended to add the host alarm function to prevent accidental touches. Users can add functions according to their needs. One key value corresponds to one function.

③ Select Playback Mode: There are five options in the this item, including single play, single loop, random play, sequential play, list loop. The playback mode is only valid for the function of "host playing music", and other functions cannot select the playback mode.

④ Add Device: Select the device to be controlled by this function task in the list, and then click the ">" button to add it to the list on the right.

⑤ Delete Device: Users can select certain devices when they are not in use according to their needs, and click the "Delete" button to delete them from the list, and then press "Save" to complete the deletion and editing of a functional task. It can be deleted individually or as a whole.

⑥ After editing, click "Save" to complete the editing of a functional task.

3) You can select the existing function task, click the "Modify" button at the bottom of the left column, users can modify the device and song according to their needs, and then press "Save" to complete the modification and editing of a functional task. The interface is as shown below:

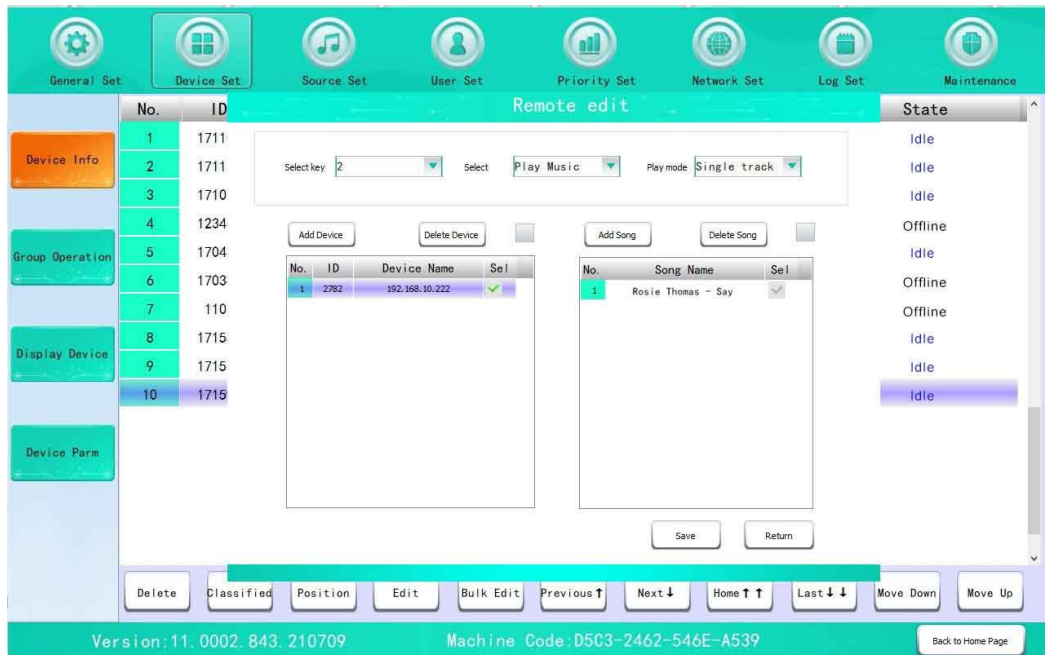

4) Users can select the edited functional task when not in use according to their needs, and click the "Delete" button to delete it from the list, and then press "Save" to complete the deletion and editing of a functional task.

5) After editing the 9 functional tasks controlled by the microphone of the wireless remote control, press the 1-8+ button within the control range of the remote control to open and execute the corresponding functional tasks. The volume of the broadcast task being played can also be adjusted through the wireless remote control microphone.

After the setting is complete, click "Save" to take effect.

- When selecting the mixing rack-type network terminal for editing, enter the interface as shown below:

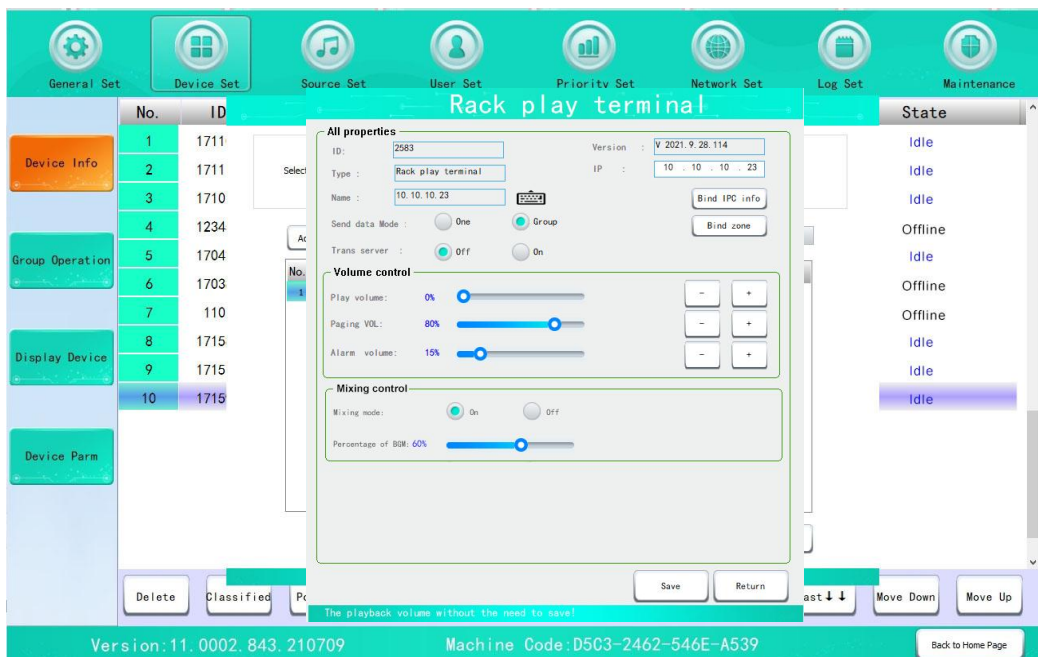

Rack-type Network Terminal Editing Interface

- (1) Terminal type: This device is a rack-type network terminal, the device type will be automatically displayed in the host and cannot be changed on the host;
 - (2) Name: Default, you can edit the name of the terminal as needed;
 - (3) IP: The IP address of device will be automatically displayed in the host, and it could be changed on the “System maintenance, Modify terminal IP” of the host, or on the terminal.
 - (4) Data Sending Mode: You can set the data sending mode as unicast or multicast.
 - (5) Transit Server: If the terminal and the requested device are not in the same network segment or the network cannot meet the condition of data bidirectionality and need to enable the transit server for the device.
 - (6) Volume Control: The rack-mounted network terminal can control the playback volume, paging volume, and alarm volume. The playback volume can take effect without saving.
 - (7) Mixing Control: It is a user-defined item, which can control whether the mixing mode is turned on and the proportion of background sound after mixing, which can be set according to requirements and needs.
- After the setting is complete, click "Save" to take effect.

(5) Bulk Edit

First select a device in the “Bulk Device Selection” column, and then tick in front of the option under “Application Selection” (for example, tick in front of the playback volume to indicate that setting the playback volume is an effective operation, and not tick in front of the playback volume to indicate that setting the playback volume is an invalid operation), and then set the parameters of “Volume Control”, “Data Sending Mode”, and “Transit Server”, and then click “Save”, as shown in the figure below.

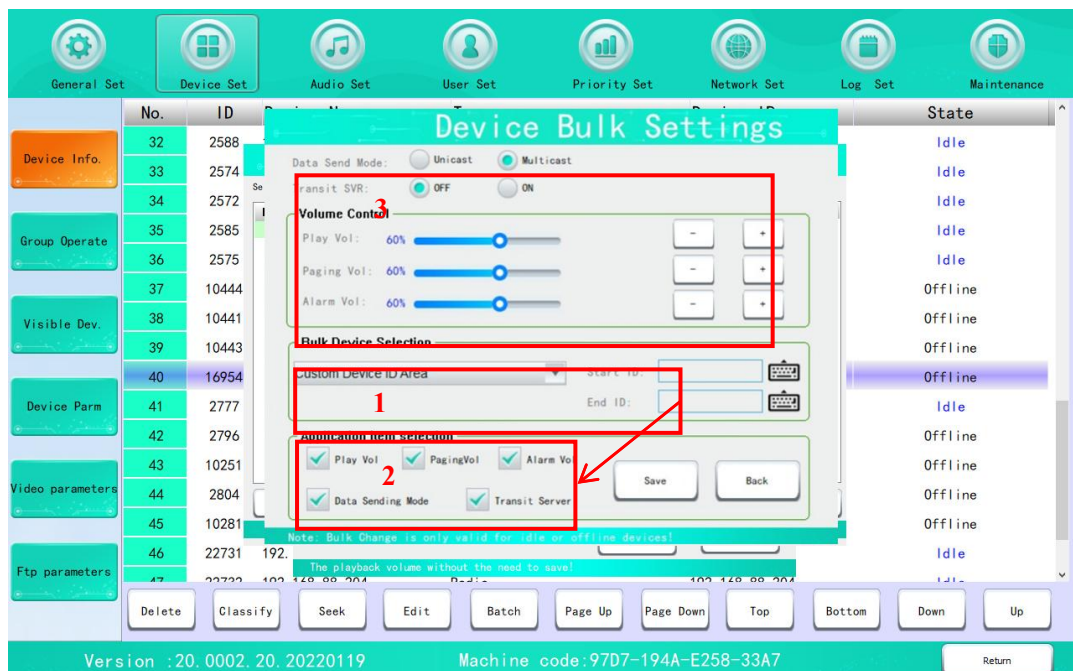

Bulk Device Settings Interface

5.2.2 Group Operation

- a. Click “Add” to enter the group name, and click “OK” to finish adding the group.

b. Select a group, for example, select the “cc” group to add a terminal device, select the terminal device to be added to the “cc” group under the “Not included devices” list, and click to add it to the “Included devices” list, as shown in the figure below. After setting, you can view the set groups in the “Group Display” at the bottom of the main interface.

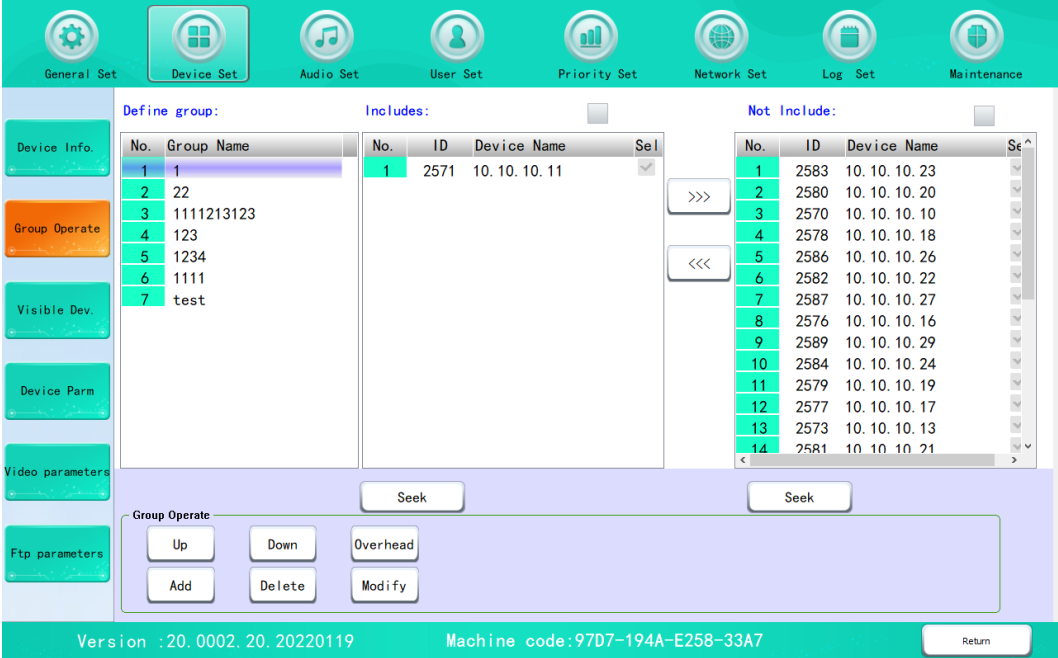

Group Operation Interface

5.2.3 Display Device

The devices under the “Displayable Devices” list are as shown in the display device interface below, and the device information can be displayed on the host interface.

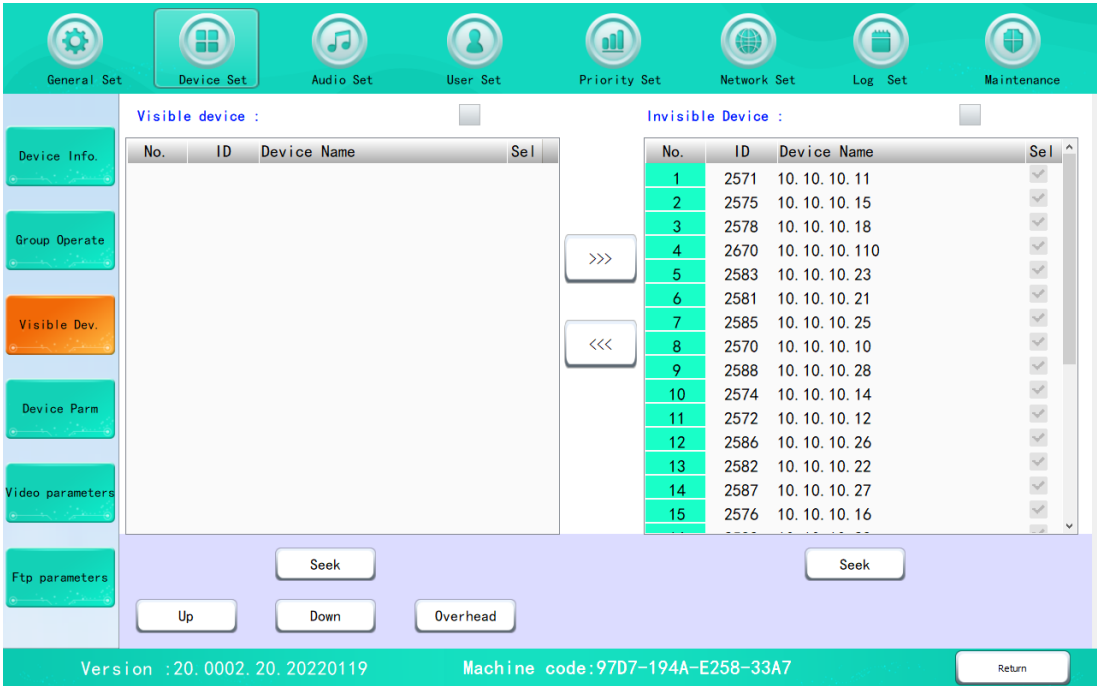

Display Device Interface

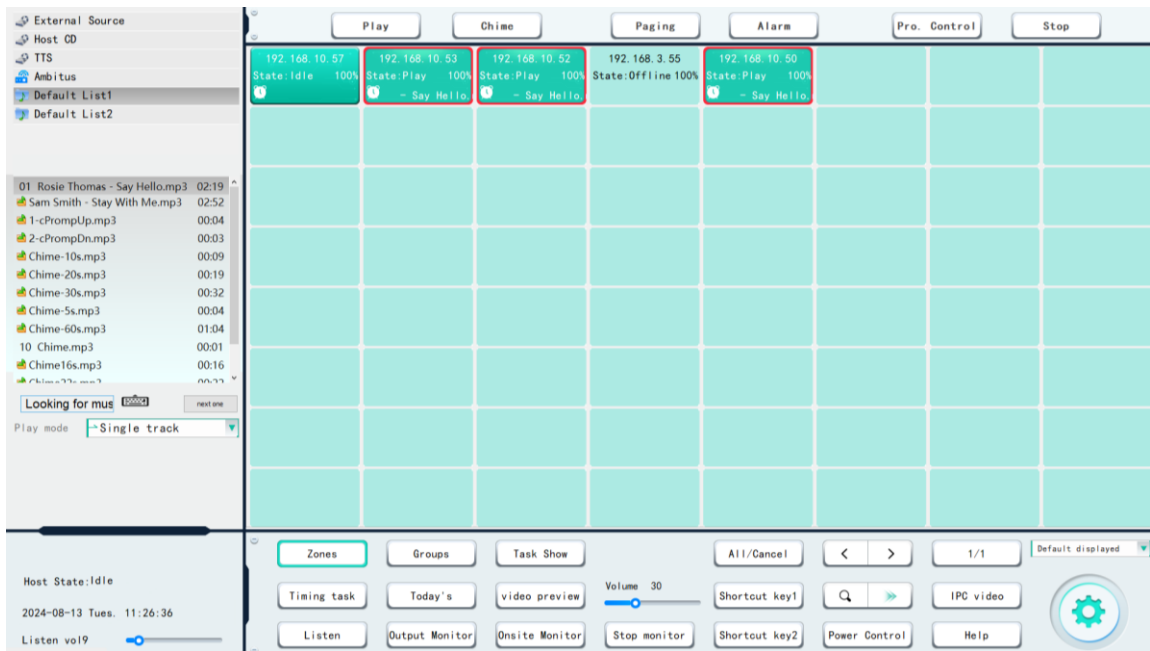

Main Interface

The devices under the “Non-displayable Devices” list are as shown in the display device interface below, and the device information can not be displayed on the host interface, as shown in the main interface below.

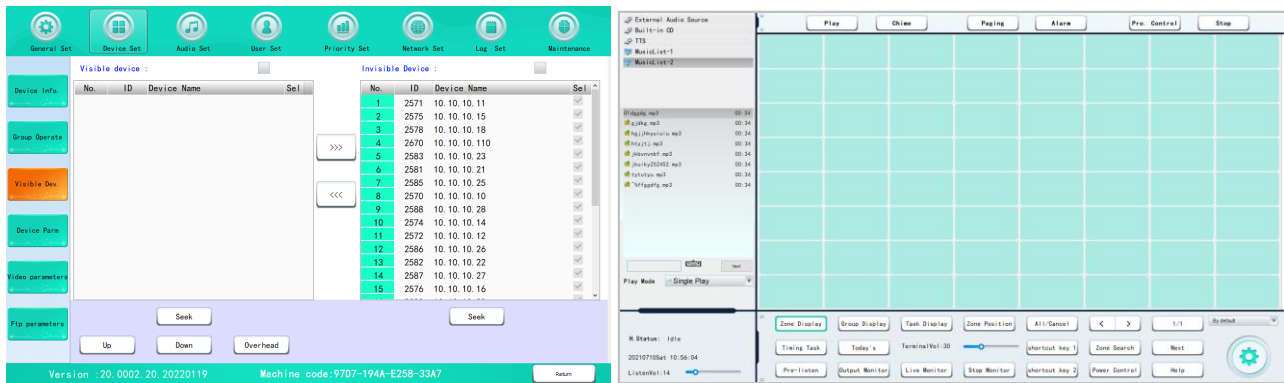

Display Device Interface

Main Interface

5.2.4 Device Parameters

Tick the corresponding output audio source in the “Terminal Overridden Output (DC-24V) / (SC-short circuit) (Rack Power Supply CH1 CH2)” column, and click “Keyboard” to set the delay off time, and then when the connected output terminal is playing the corresponding audio source (like host paging), the output terminal “Terminal Overridden Output (DC-24V) / (SC-short circuit) (Rack Power Supply CH1 CH2)” is triggered, and when the connected terminal stops playing the corresponding audio source, the triggered output terminal “Terminal Overridden Output (DC-24V) / (SC-short circuit) (Rack Power Supply CH1 CH2)” will be closed after a set delay time.

Set the time in the “Host rear panel output power and terminal power timing control operation” column as shown in the figure below. Click the “Keyboard” to set the time, that is, the system will automatically start the control

operation of the host and terminal 15s before the timing point. Then click the “Save” button to take effect, as shown in the figure below.

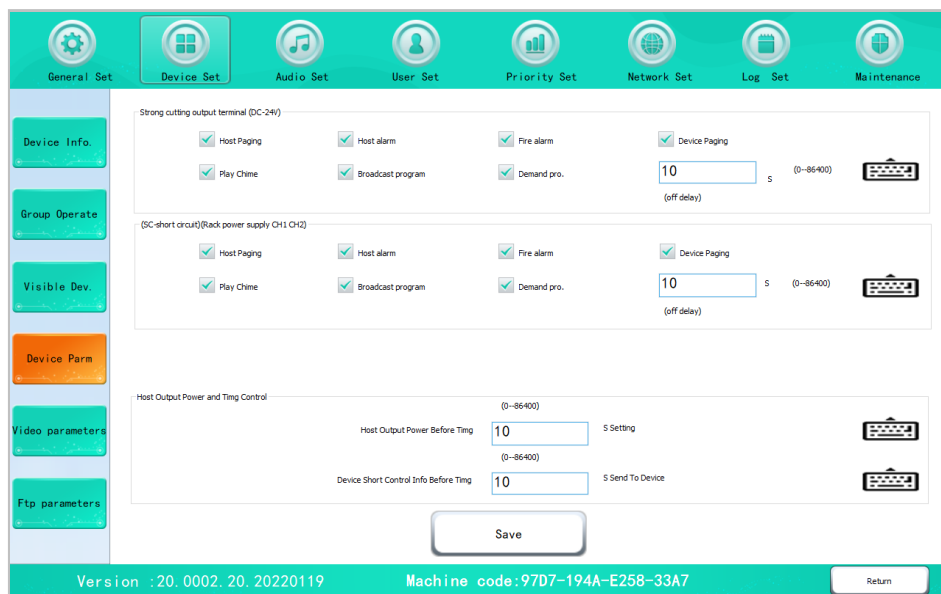

Device Parameters Interface

5.2.5 Video Device Parameters

Video users can be set in the interface of "video equipment parameters", and the terminal with video function can realize video intercom function by logging into the same video user. Click the "New User" button to enter the user name and password in the pop-up interface, and then click the "OK" button, and then set the maximum preview window (4 split screens, 6 split screens, 8 split screens or 9 split screens) and resolution size, click "Save", and the video user can be modified and deleted after saving it, as shown in the figure below;



Video Device Parameters Interface

5.2.6 Ftp Parameters

In "Ftp Parameters", you can add Ftp server account to access the streaming server and achieve related functions, click "Add" button to enter Ftp server, user name, password and port in the pop-up interface, and click "Save" button, as shown in the figure below;

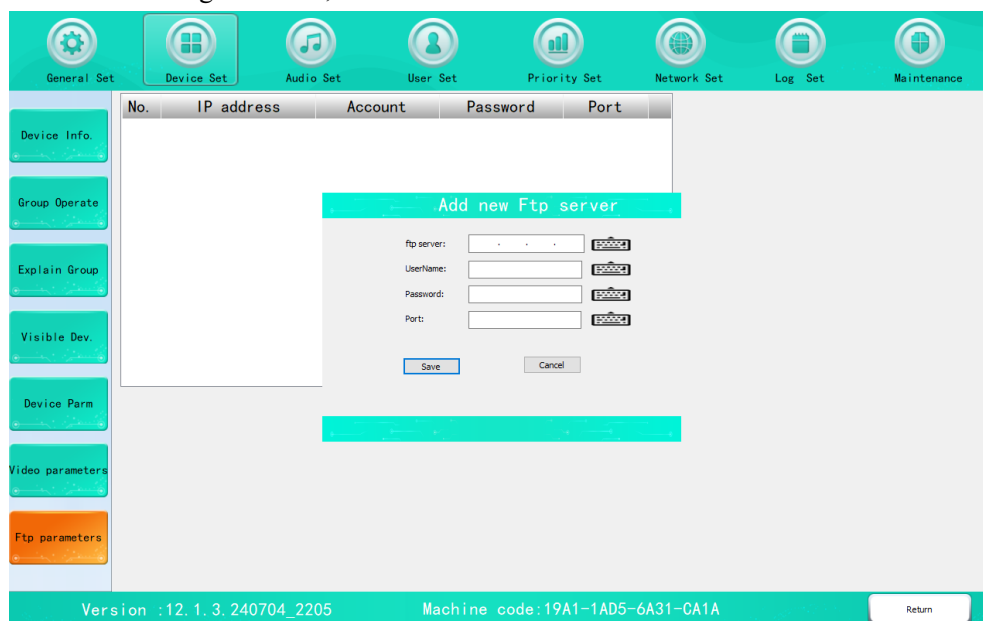

Ftp Parameters Interface

5.3 Sound Source Management

In the "System Settings" interface, click the "Sound Source Management" button to enter the "Sound Source Settings Management" interface. On this interface, you can edit the functions such as playlist, host songs, USB songs, program recording, alarm sound settings, chime settings, and sound card configuration.

5.3.1 Playlist

New List:

Click the "New List" button to enter the list name, and click the "OK" button to create a new list name successfully, as shown in the figure below.

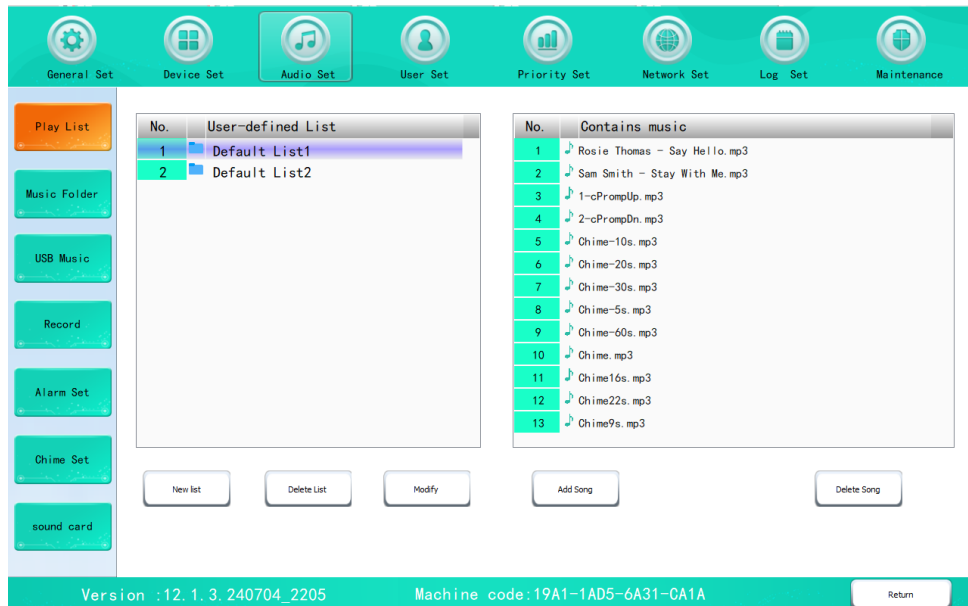

New List Name Interface

Add Song:

Select a list, click “Add Song” to enter the add song dialog box, select the host music directory, select a song, and click the button to add a song; as shown in the figure below.



Add Song Interface

5.3.2 Host Song

New Directory: Click “New Directory” to enter the directory name, and click the “OK” button to create a new directory, as shown in the host songs interface below.

Delete Directory: Select a directory list and click “Delete”.

Modify Name: Click “Modify Name” to modify the directory name.

Delete Song: In the “Included Music” column on the right, select the song to be deleted, and click “Delete Song”

to delete the song successfully.

Add Song: Click Add Song to enter the “Add Song” dialog box, click  to select the song path, select the song directory to be added, click OK, then tick the song to be added, and finally click “Add” to add the song successfully, as shown in the figure below; the host songs can also be copied in via a USB flash disk. Please refer to the description of “USB Songs” for specific operations.

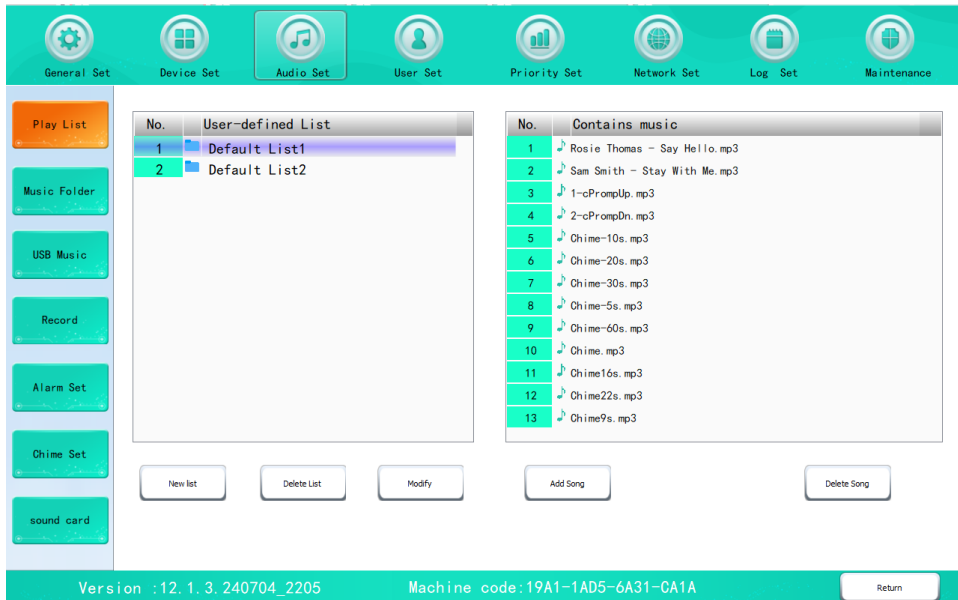

Host Songs Interface

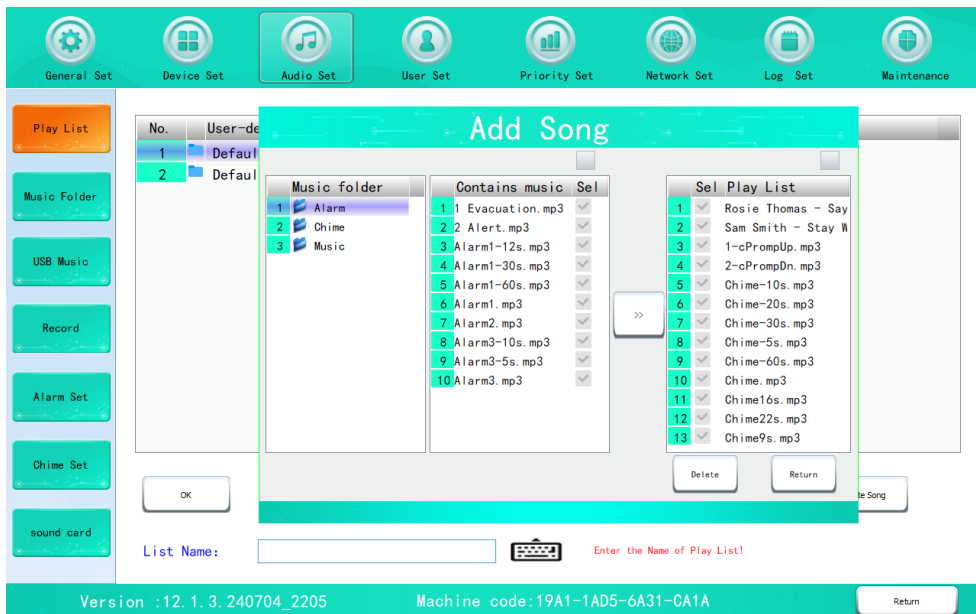

Add Song Interface

5.3.3 USB Song

First download the songs to the USB flash disk, then insert the USB flash disk, wait for the host to detect the song, and after “USB Ready” is displayed, select the host music directory, and finally click the button  to copy the songs to the host, as shown in the figure below.



USB Song Interface

5.3.4 Program Recording

Click “Start Recording”, and then start recording the content you want to record, click “Stop Recording” → “Pre-listen to Recording”, and after trial listening and confirming the recording content, click “Save Recording”, as shown in the figure below.

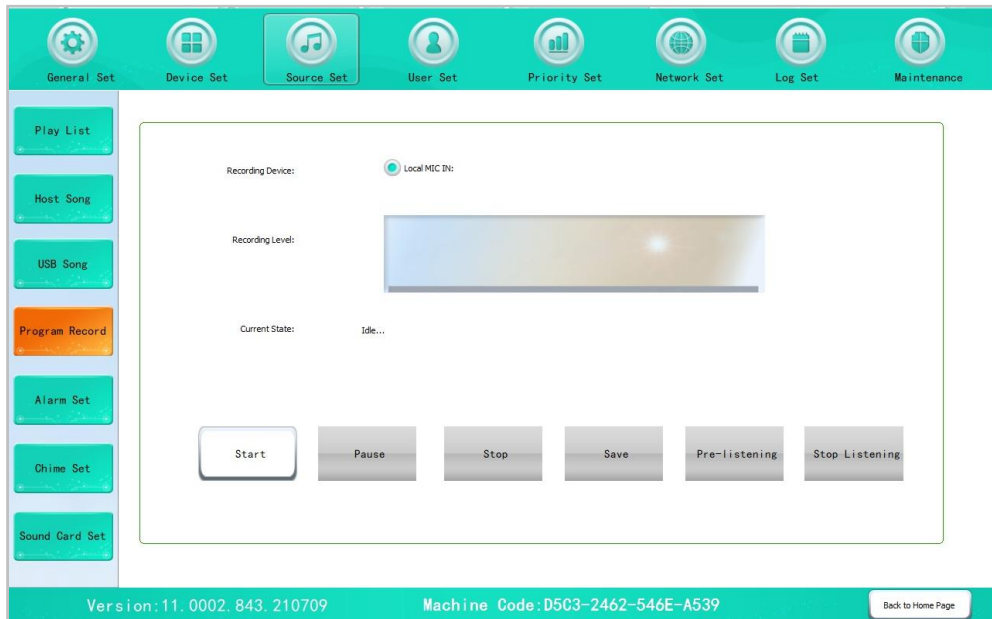

Program Recording Interface

5.3.5 Alarm Sound Settings

Click the “Alarm Sound Settings” button, select “Alarm Sound” in the song directory of the interface, and then select the alarm sound source. If you do not set the alarm music or click the “Restore Factory Alarm Sound” button, it will play the factory default alarm sound, as shown in the figure below.

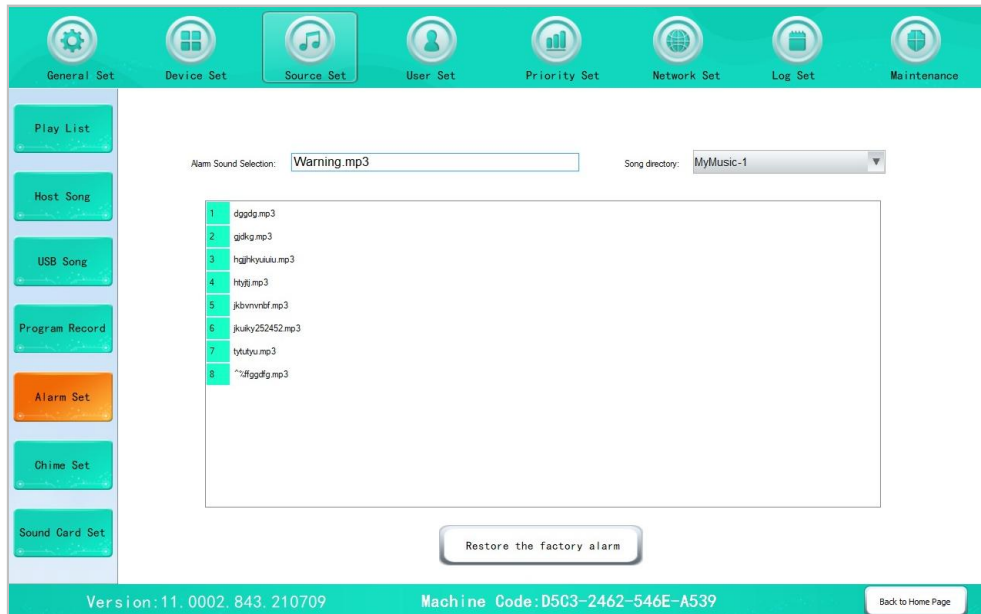

Alarm Sound Settings Interface

5.3.6 Chime Settings

Click the “Chime Settings” button, select “Chime” in the song directory of the interface, and then select the chime music, if you do not set the chime music or click the “Restore Factory Chime” button, it will play the factory default chime, as shown in the figure below.

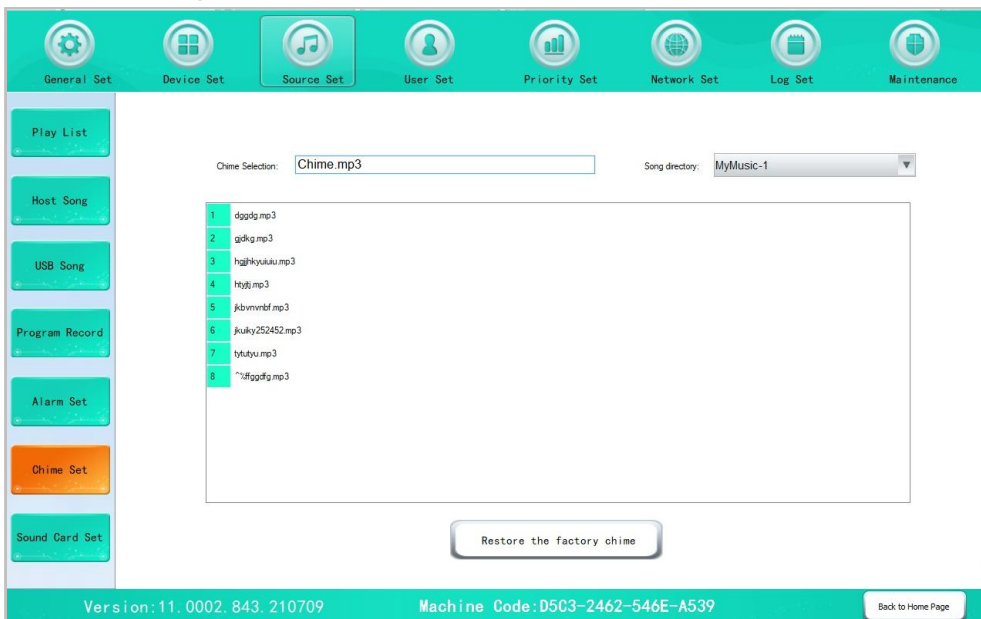

Chime Settings Interface

5.3.7 Sound Card Configuration

Click the “Sound Card Configuration” button to set the emergency microphone sound card and output sound card on the host, as shown in the figure below.



Sound Card Configuration Interface

5.4 User Management

5.4.1 New User

Click “New User” to pop up the “New User” dialog box, enter the user name and password and set user permissions, click OK to create a new user account, and the system automatically assigns the PC sub-control device number and mobile phone device number, as shown in the figure below.

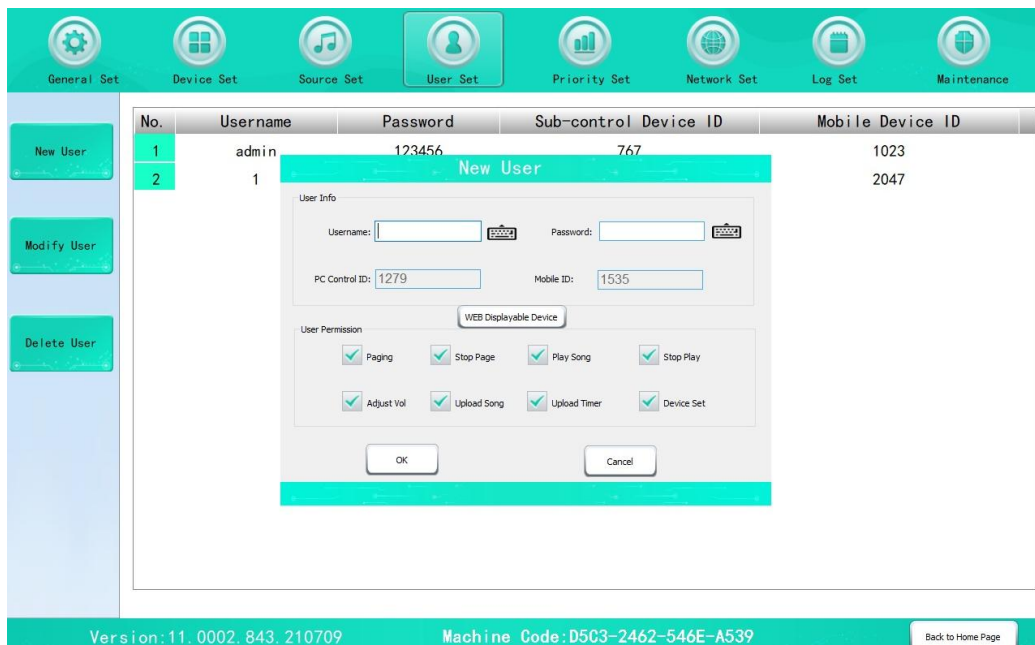

New User Interface

5.4.2 Modify User

Select a user name, click “Modify User” to enter the corresponding dialog box to modify user information and

user permissions, as shown in the figure below.

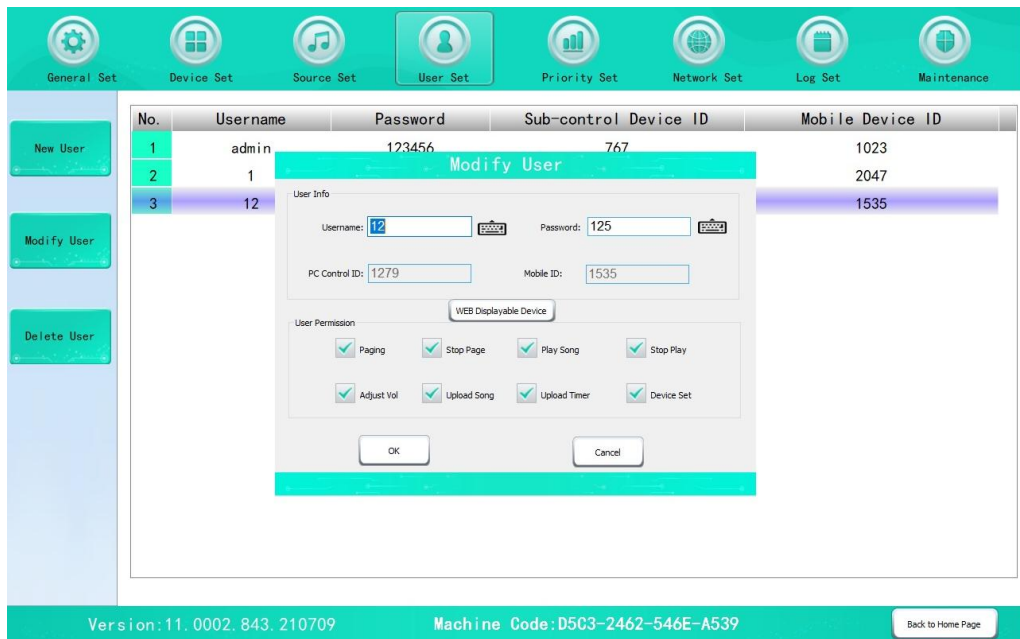

Modify User Interface

5.4.3 Delete User

Select a user account, click “Delete User” and then click “OK” to delete the user successfully, as shown in the figure below.

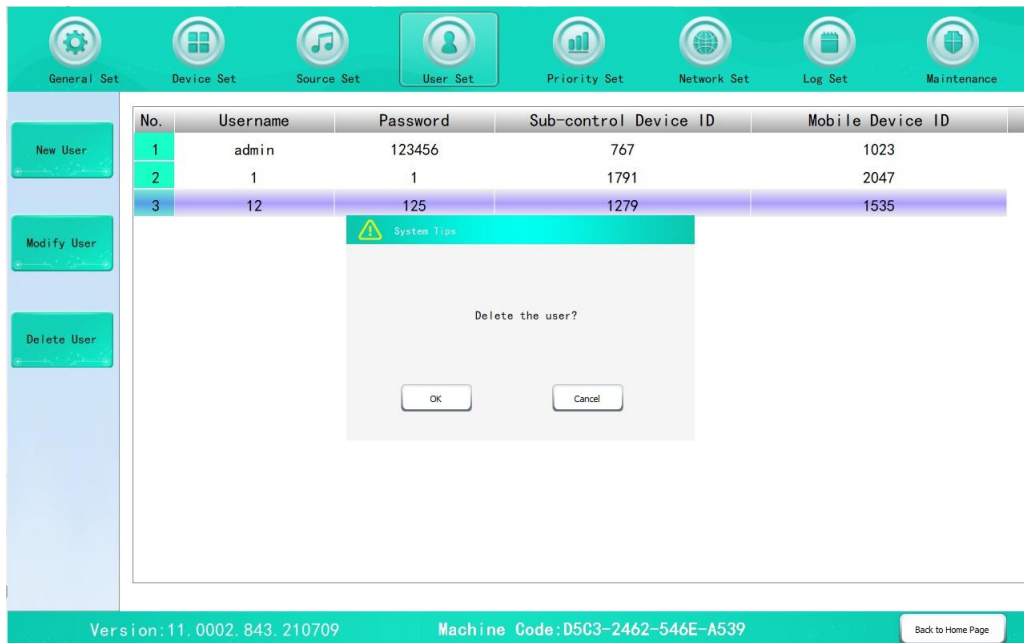

Delete User Interface

5.5 Priority Settings

The factory default priority setting is shown in the figure below.

Note: The priority is gradually reduced from 1-8, the one with higher priority can interrupt the one with lower priority. For example, “Broadcasting program” is level “7”, “Timing program” is level “6”, when the

“Broadcasting program” is working and it is time to play the “Timing program”, the “Timing program” will start to work, and the “Broadcasting program” will be interrupted, and when the “Timing program” ends, the “Broadcasting program” will be restored to the previous working status.

Click the gray inverted triangle behind the function name to select the priority of the function.

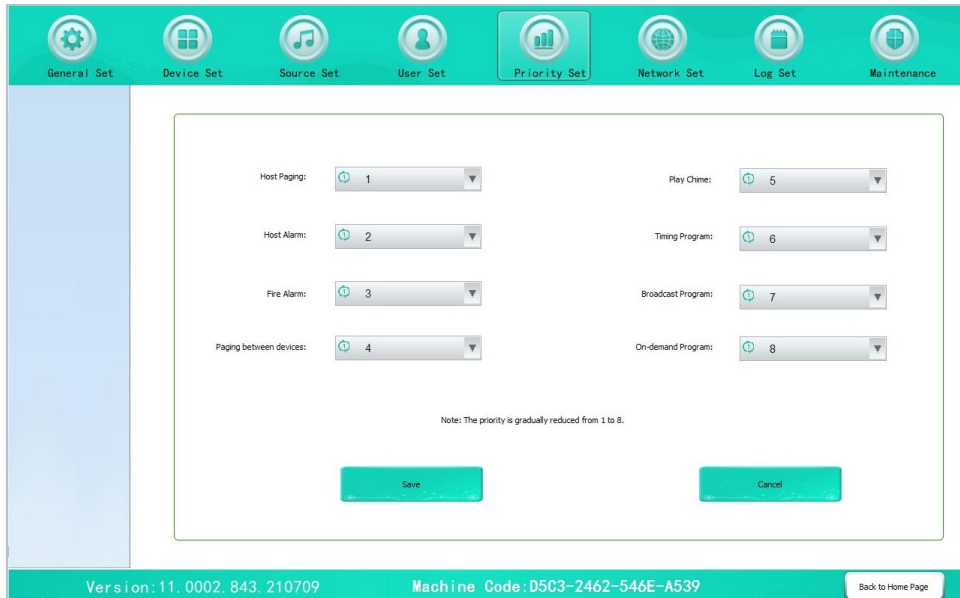

Priority Settings Interface

5.6 Network Settings

5.6.1 IP Management

“Add IP/Gateway”

Click the “Add IP/Gateway” button to pop up the “Add IP/Gateway” dialog box, enter the IP segment/gateway of the terminal, for example, 192.168.20.250, and click the “OK” button to add the terminal IP/gateway of 192.168.20.250 network segment successfully, as shown below.

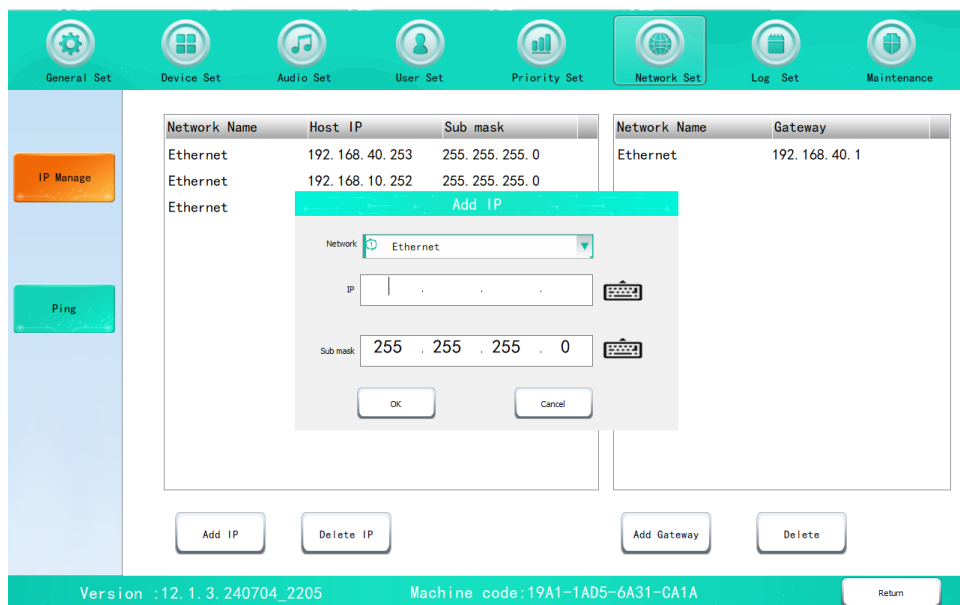

Add IP Address Interface

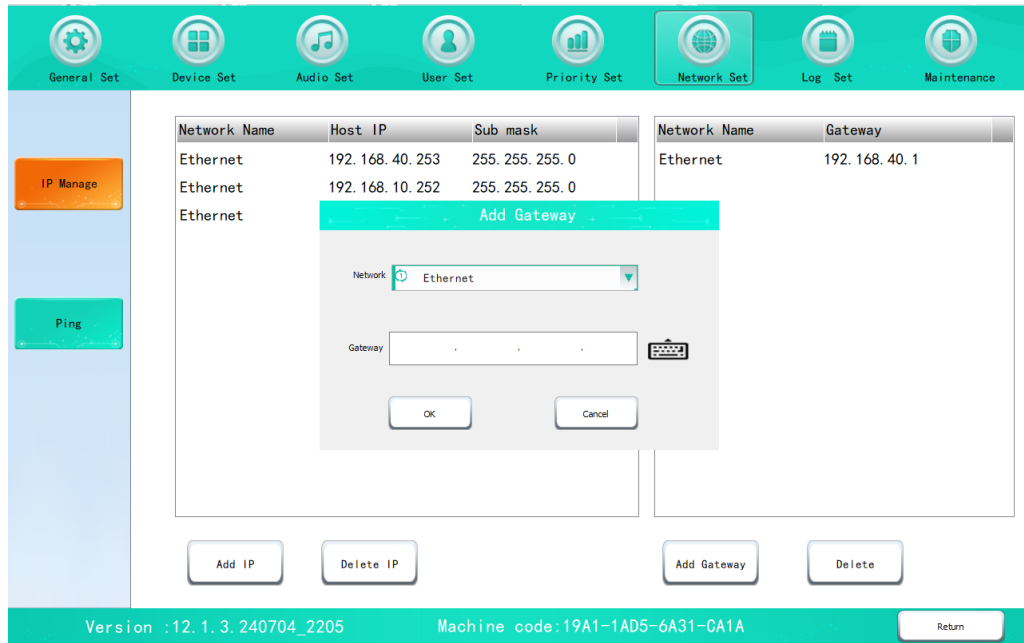

Add Gateway Interface

5.6.2 Ping

Click the “Ping” button to enter the Ping IP dialog box, enter the IP to be pinged, and click the “Start” button to start “Ping”. If “Request timeout” appears, it means that the IP is not connected successfully, as shown in the figure below.

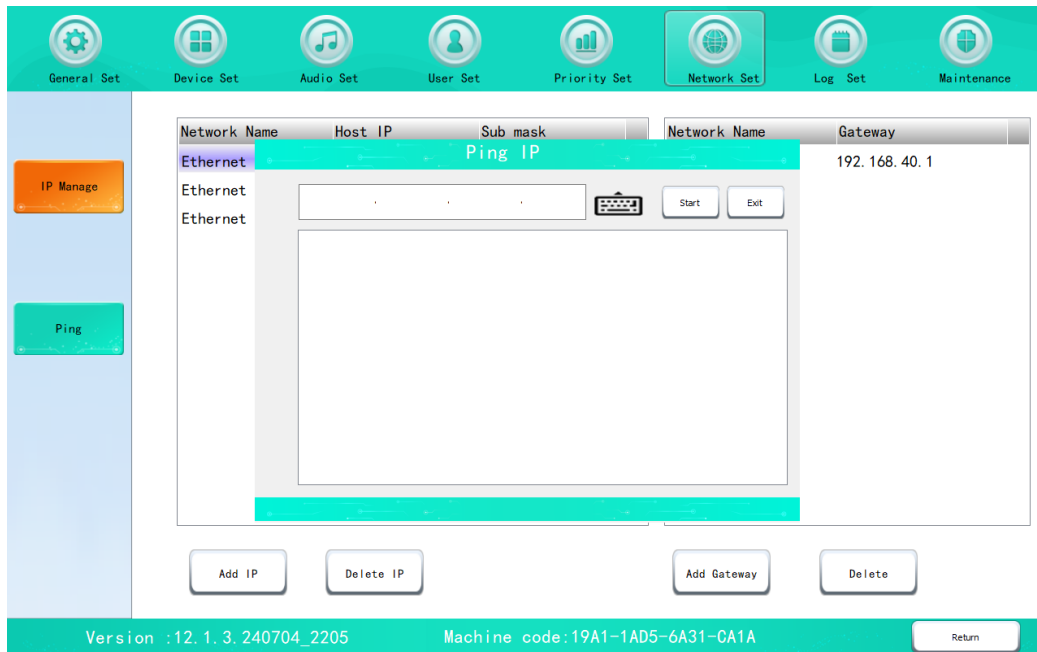

Ping Interface

5.7 Logs Management

5.7.1 Server Logs

Under “Log Type”, you can select system logs, operation logs, and fault logs. Under “Subtype”, you can select the

type and status of the playback audio source, set the query time range, namely “Start time” and “End time”, and click “Query” or “Export” button to view the currently filtered logs or export them to a USB flash disk, as shown in the figure below.

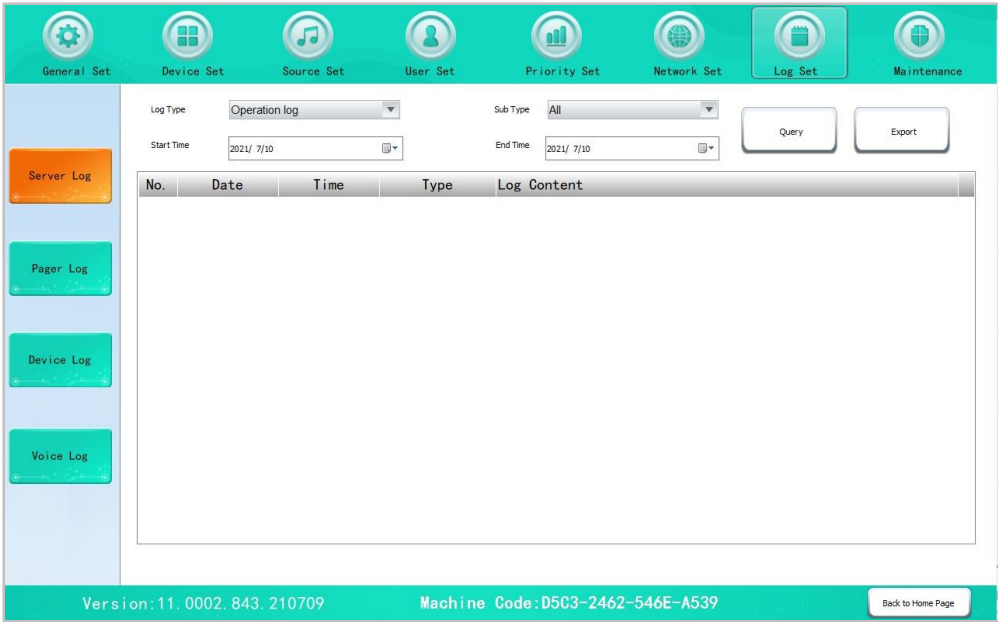

Server Logs Interface

5.7.2 Paging Station Logs

Save paging station logs to server:

When “Save paging station logs to server” is ticked, there is no way to select “Log save directory”. When “Save paging station logs to server” is not ticked, the paging station logs will be uploaded to the server. If it is not ticked, the paging station logs will not be uploaded to the server, as shown in the figure below.

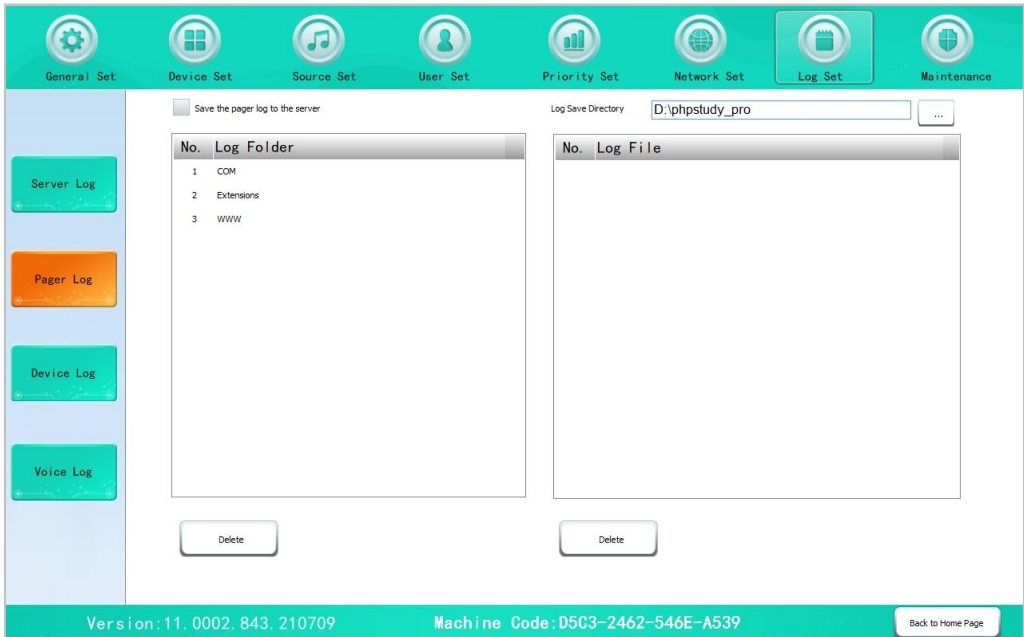

Paging Station Logs Interface

Log save directory:

When the “Save paging station logs to server” is not ticked, you can select the log save directory, click the button , and select the save path directory, as shown in the figure below.

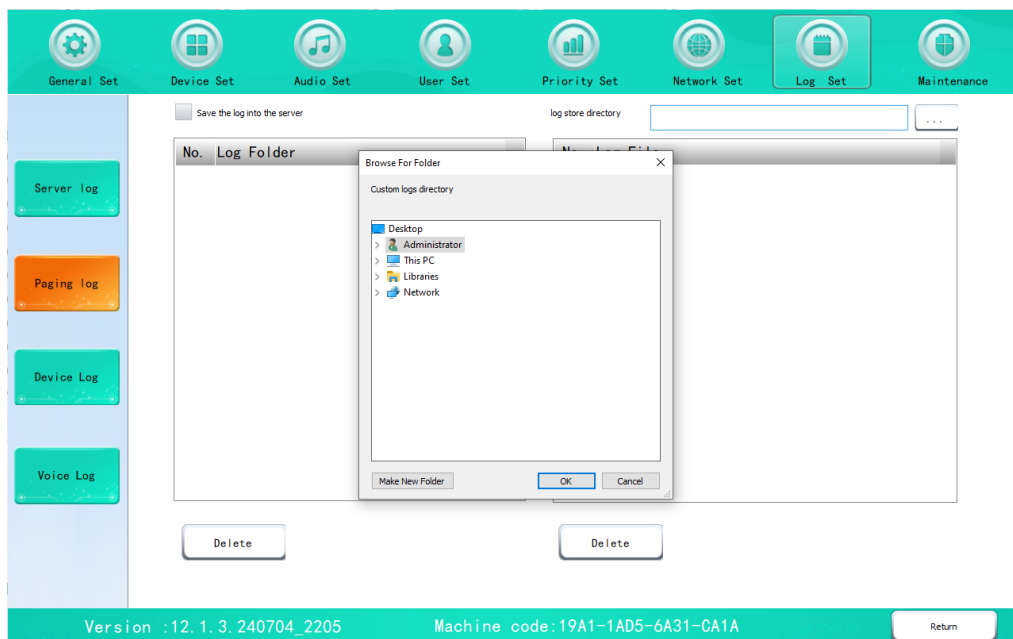

Log Save Interface

5.7.3 Device Logs

Under “Log Type”, select online logs, offline logs or logs by device number (you need to enter the device number), set the start time and end time, and click “Query” to query the device, as shown in the figure below.

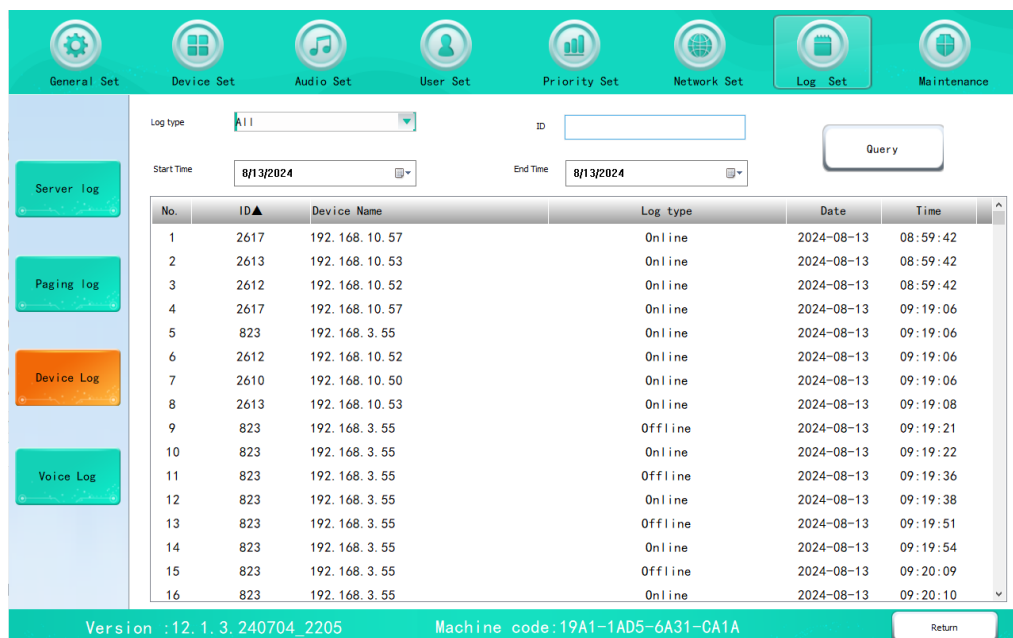

Device Logs Interface

5.7.4 Voice Logs

According to customer needs, set whether to synchronize the host microphone recording, and whether to perform pre-listening and recording operations on the voice logs interface, as shown in the figure below.

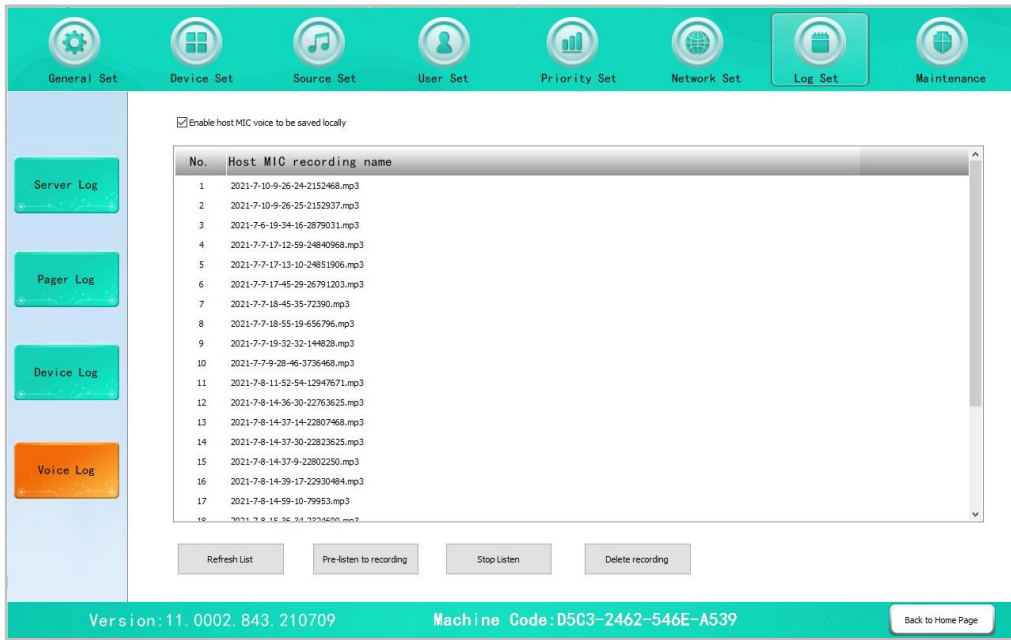

Voice Logs Interface

5.8 System Maintenance

5.8.1 Smart Paging Station

Click “Paging Station”, tick the box in front of “Upgrade”, then click the “Select” button, select the upgrade program, and then enter the IP number of the terminal to be upgraded, select the IP number, and then click Upgrade as shown in the figure below.

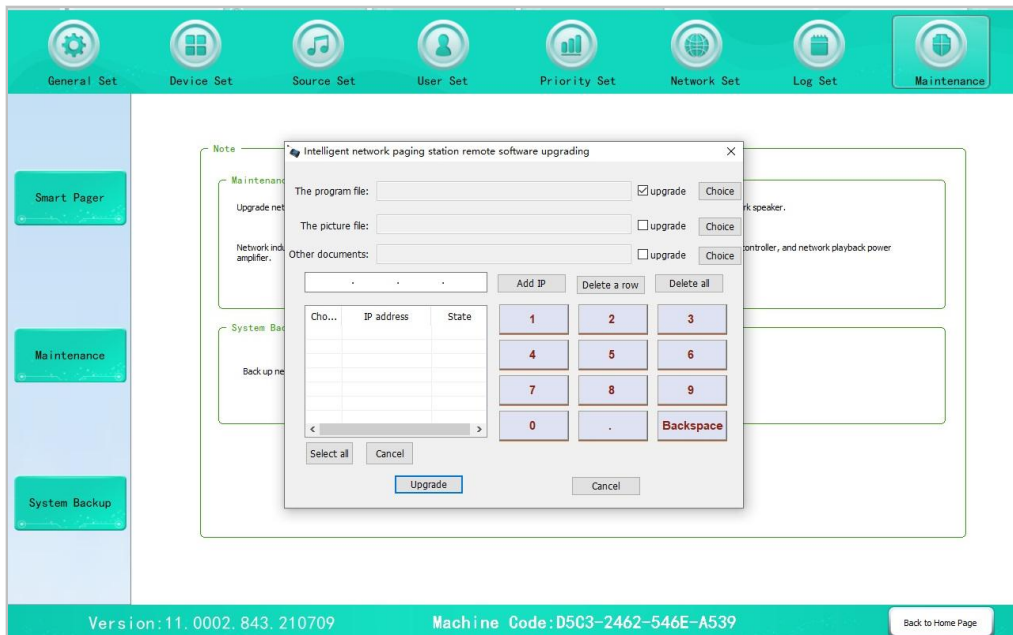

Smart Paging Station Interface

5.8.2 Device Maintenance

Modify IP: If there is a terminal IP conflict:

Select “Auto Search” or “Specify IP”, click “Search”, select one of the devices when the terminal IP appears, and then click “Modify IP” to pop up the corresponding dialog box, enter the new IP address, remain the subnet mask, default gateway, server IP address and standby server IP address unchanged, and tick “Modify” for the parameter that needs to be modified, and click “OK” to take effect, as shown in the figure below.

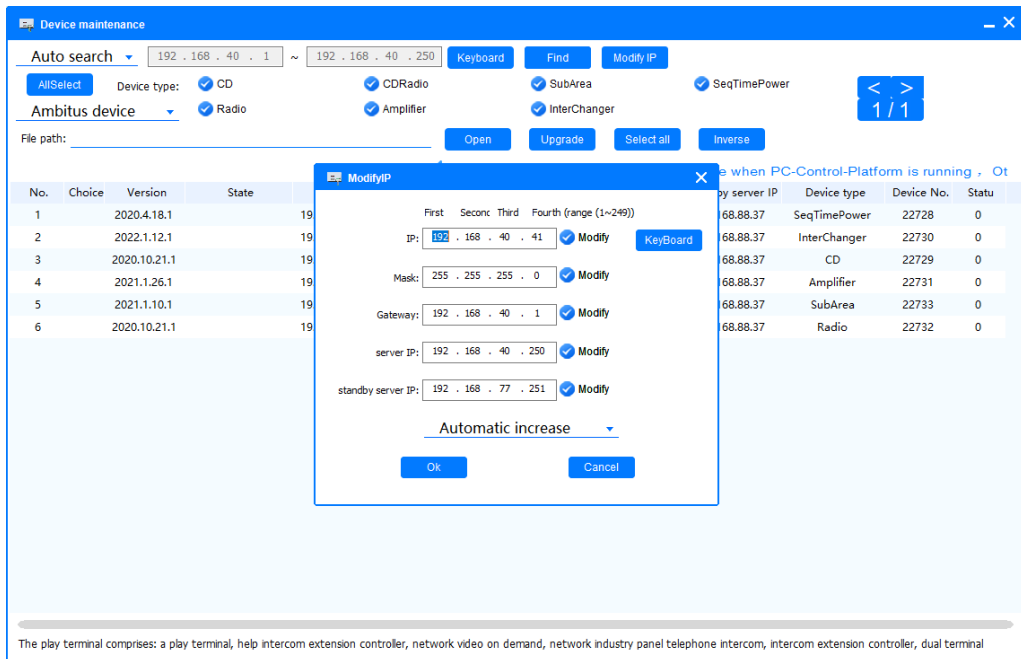

Device Maintenance Interface

Upgrade:

Select “Auto Search” or “Specify IP” and click “Search”, select one of the terminal IPs when the terminal IPs appear, click the “Open” button behind the “File Path”, select the upgrade program file, and click Upgrade to upgrade successfully, as shown in the figure below.

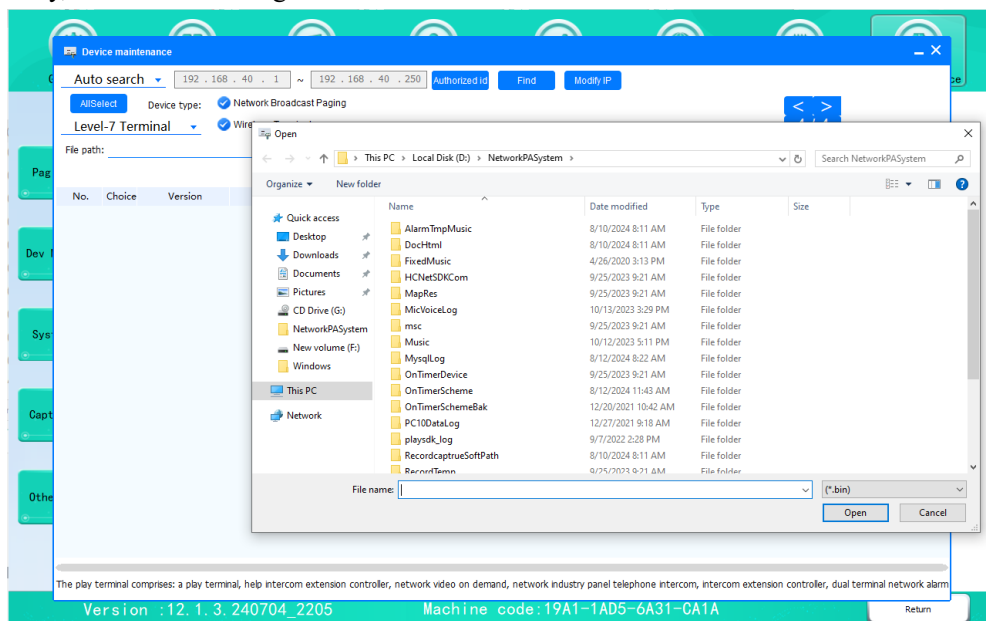

Upgrade Interface

5.8.3 System Backup

Click “System Backup” and click “OK” to enter the upgrade backup dialog box, select the backup path, and click “Start” to back up successfully, as shown in the figure below.

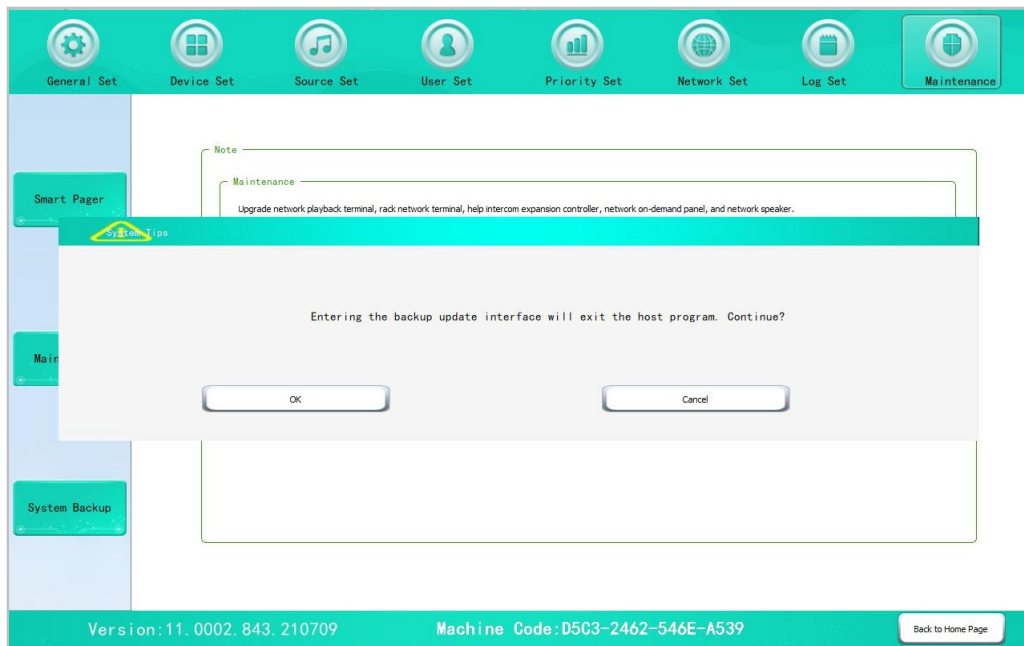

System Backup Interface

5.8.4 Capture / Record

“Capture / Record” item can record video and interface screenshots of host software operations. Click "Capture / Record" to pop up the tool box as shown below. The tool functions are to record the operation video, edit and view the screen recording file, select the save path of the screen recording file, capture screen shots and exit.



Capture / Record Interface

1. Safety Precautions

- Please do NOT connect this device to the power source, before the system is correctly wired.
- It is important to ensure that input voltage to the device is the same as required voltage of the device, otherwise the device may be damaged.
- There is dangerous voltage in the device, which may cause personal electric shock. Please do NOT open the case without permission, to avoid potential risks of electric shock.
- The device is not completely disconnected from power source when it is switched to “OFF”. For sake of safety, please disconnect the device from the socket if it is not in use.
- Please do NOT place the device where it is extremely cold or hot.
- Good ventilation must be provided in the working environment of the device, to avoid excessive temperature during its operation, which may cause damages to the device.
- Please unplug the device from power socket in raining and wet days or if the device is not in use for a long time.
- Please disconnect the power plug from sockets, to ensure the device has been completely disconnected from power source, before any component is removed from or re-installed in the device or before any electric connector of the device is disconnected or reconnected.
- In case of any failure of the device, please do NOT open the case and repair without permission from a professional personnel, to avoid accident or additional damages to the device.
- Please do NOT place any corrosive chemicals near or on the device.

2. Matters needing attention

- Our company provides a three-year free warranty service (including free replacement parts) over quality issues as from the date of purchase, provided that the device is installed and used in accordance with requirements specified in the User Manual.
- For warranty, the user must show the Warranty Card and the receipt kept by the user and purchase invoice of the device as supporting documents.
- The following conditions are beyond the scope of warranty:
 1. Product damage due to improper installation, use or handling;
 2. Product damage due to abnormal conditions (such as excessive power source voltage or ambient humidity);
 3. Product damage due to natural disasters;
 4. Product SN is changed, altered or removed;
 5. Product has been repaired or modified by any person without duly authorization from our company;
- Please keep the User Manual and Warranty Card in good custody.
- For issues and precautions not mentioned in this User Manual, if required, please contact the distributor or visit our website.
- In case of any failure in the warranty period, please contact service personnel (or distributor) of our company for service. The company shall not be liable for damages due to unauthorized dis-assembly or maintenance or service by unauthorized personnel.

Packing List

No.	List	Quantity
1	Network Host	1 piece
2	Universal Infrared Remote Controller	1 piece
3	User Manual	1 copy
4	Washer	4 pieces
5	Audio Cable with RCA	1 piece
6	3m Network Cable	1 piece
7	Cross Recessed Raised Countersunk Head Screw	4 pieces
8	Audio Converter	5 pieces
9	Power Cable	2 pieces
10	10P Green Plug 2.5MM	2 pieces
11	Power-on Key	2 pieces
12	CB100 Microphone (With Plug)	1 piece
13	2P Green Plug	1 piece
14	Switch Module (Standard)	1 piece
15	4-channel Audio Collection Module (Standard)	1 piece
16	Monitor Module (Standard)	1 piece
17	Hard Disk Module (Standard)	1 piece
18	Main Power Expansion Module (Standard)	1 piece
19	Standby Power Expansion Module (Standard)	1 piece
20	Telephone Paging Module (Optional)	1 piece
21	32-channel Fire Linkage Module (Optional)	1 piece

Appendix Specifications

Model	CNS6182II
Computer System	WIN7 and above
CPU	Intel(R) Core(TM)I7-7600U
Memory	8G DDR4
Hard Disk Capacity	250G M.2 SSD +512G 2.5-inch SSD
Audio Playback Format	MP3
Play Stream	120k-320K
Operating System	32/64 bits
Number of Terminals Supported by Network	Less than 110 unicast, unlimited multicast
Screen Size	17.3" LCD screen
Control Method	Touch screen
Timing Power Load Capacity	Single channel current: 2A
System Audio Signal SNR	LINE: >70dB; MIC: >60dB
System Audio Signal Distortion	1kHz<0.5%
System Audio Signal Standard Input Level	LINE: 300mV±20mV; MIC: 10mV±2mV.
System Audio Signal Standard Output Level	0dBV
Power Output Method	Constant resistance output
Undistorted Output Power	10W
Power Consumption	AC 220V/50Hz/150W
Package Dimensions (L×W×H mm)	535×360×540
Machine Dimensions (L×W×H mm)	483×445×308
Gross Weight	28.7kg
Net Weight	19.5kg
System Software	Network PA system software package. All rights reserved, no copying or counterfeiting is allowed.

The specifications will be subject to changes without notices.

CAUTION

- When the power switch is “OFF”, the machine is not completely disconnected from the power grid. For the sake of safety, please pull the power cord plug out of the socket when not using the equipment.
- The equipment shall not be subject to water drops or splashes, and objects such as vases filled with water shall not be placed on the equipment.
- To reduce the risk of electric shock, do not remove the cover. If necessary, please ask professional personnel to repair.
- The symbol ⚡ on the rear panel indicates hazardous live. The connection of these terminals must be operated by the instructed person.
- The equipment is connected to the power grid through the power cord plug. In case of equipment failure or danger, the connection between the unit and the power grid can be disconnected by pulling out the power cord plug. Therefore, it is required to place the power socket to a position where the power cord can be plugged and unplugged conveniently.